



Technology for Vacuum Systems

Instructions for use

Customized equipment HP 40B

Attention: Please observe the notes in the supplementary sheet.

2612089

Notice: Customized equipment

Date: 27.05.2009

Equipment (Product): HP 40B - 230 V 50/60 Hz

Material No.: 2612089

Instructions for use for the standard equipment: HP 40B / AX 65 / RZ 6



The customized product identified above is based on a standard product which has been modified following the customer's requirement for modification. Therefore, certain features of the customized product are different from those of the corresponding standard product. In general we do not have sufficient experience whether the modifications made meet the customer's requirements. It is the customer's responsibility to check the suitability of the equipment for the intended application *prior* to use.

The instructions for use of the standard product are enclosed.

It is the user's responsibility to check very carefully if specific information given in the instructions for use can be applied to the customized product.

In particular, the following differences have to be considered:

Pumping unit HP 40B with rotary vane pump RZ 6.

An oil mist filter for installation at the outlet of the rotary vane pump RZ 6 is separately packed. Pay attention to the notes on assembling the oil mist filter in the instructions for assembly „Accessories for rotary vane pumps“.

Read and obey the instructions for use for the pumping unit, the diffusion pump and the rotary vane pump.

Rated input current 50/60 Hz: 3.2 A

Power draw (230V 50/60 Hz): 736 VA

Weight: 30.9 kg

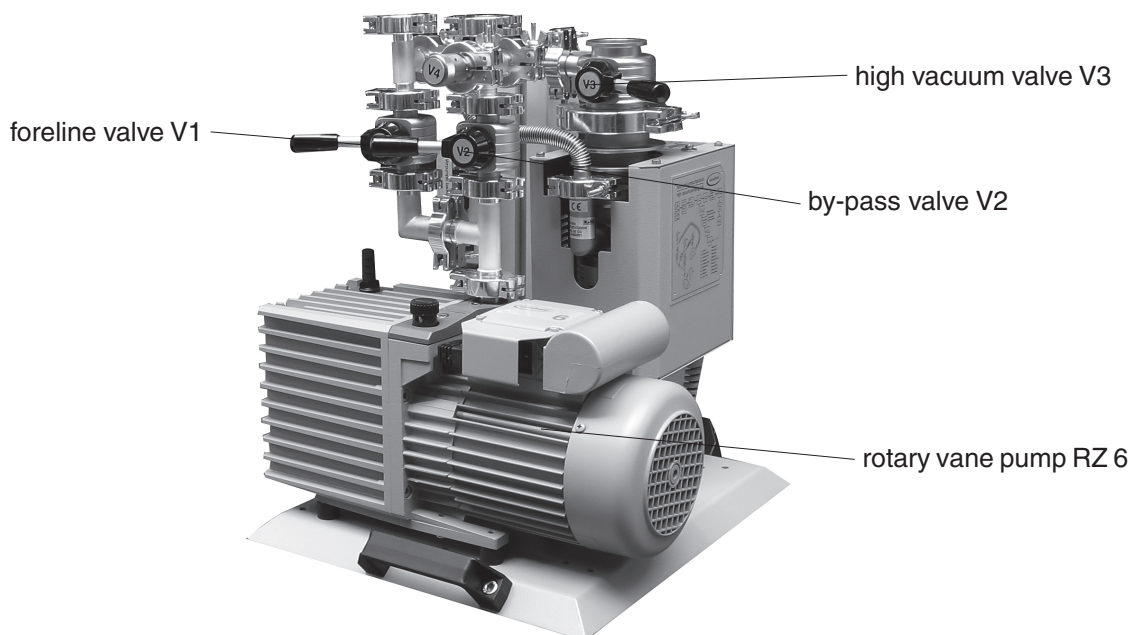



Technology for Vacuum Systems

Instructions for use

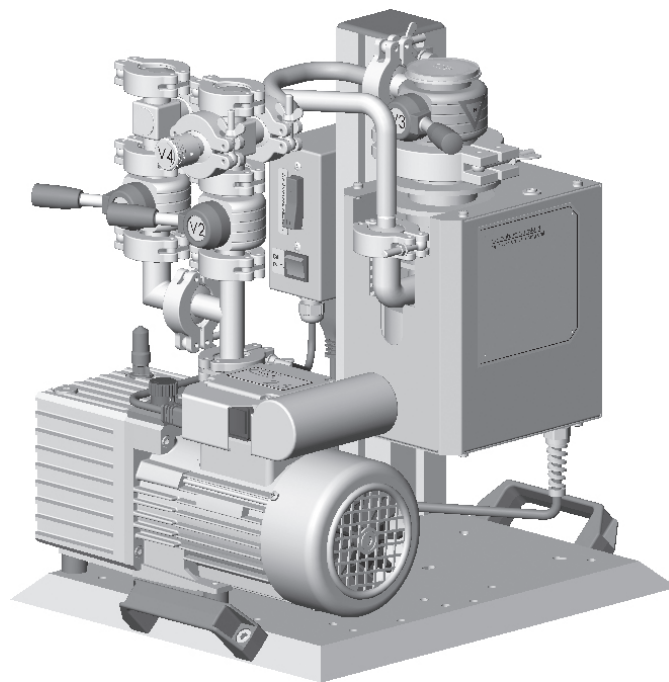

**HP 40B2
HP 63B2**

Vacuum pumping units

Dear customer,

Your VACUUBRAND pumping unit should support you for a long time without trouble and with maximal power. Thanks to our long practical experience we have much information how you could ensure powerful application and personal safety. Please read these instructions for use before the initial operation of your pumping unit.

VACUUBRAND vacuum pumps are the result of many years of experience in construction and practical operation of these pumps combined with the latest developments in material and manufacturing technology.

Our quality maxim is the "zero fault principle":

Every vacuum pumping unit leaving our company is tested intensively including an endurance run of 24 hours. Therefore also faults, which occur rarely, are identified and can be eliminated immediately.

The achievement of the specifications after the endurance run is tested for every pumping unit.

Every VACUUBRAND pumping unit achieves the specifications. We feel obliged to this high quality standard.

We know that the vacuum pump can not take a part of your real work and hope that our products contribute to an effective and trouble-free realisation of your work.

Yours

VACUUBRAND GMBH + CO KG

After sales service: Contact your local dealer or call +49 9342 808-193.



Attention! Important notes!



Not permitted! Misuse may cause damage.



Caution! Hot surface!



Isolate equipment from mains.



Note.

Contents

Safety information!	4
Technical data	8
Use and operation	10
Vacuum connection diagram	11
Troubleshooting	12
Maintenance	12
Notes on return to the factory	13
Health and safety clearance form	14

Safety information!



Remove all packing materials, remove the product from its packing-box, remove the protective covers from the inlet and the outlet ports and inspect the equipment. If the equipment is damaged, notify the supplier and the carrier in writing within three days; state the item number of the equipment together with the order number and the supplier's invoice number. Retain all packing materials for inspection. **Do not use the equipment if it is damaged!** If the equipment is not used immediately, replace the protective covers. Store the equipment in suitable conditions.

☞ Read and obey the instructions for use for the rotary vane pump and the diffusion pump before installing or operating the equipment.

Use the pumping unit only as specified in the instructions for use for the generation of vacuum.

- ☞ Make sure that the individual components are only connected, combined and operated according to their design and as indicated in the instructions for use.
- ☞ **Ensure that no part of the human body comes in contact with the vacuum.**
- ☞ Transport the pump at the provided handles.

Obey **national safety regulations and safety requirements** concerning the use of vacuum and electrical equipment.

- ☞ Equipment must be connected only to a suitably fused and protected electrical supply and a suitable earth point. Failure to connect the motor to ground may result in deadly electrical shock.
- ☞ The supply cable may be fitted with a moulded European IEC plug or a plug suitable for your local electrical supply. If the plug has been removed or has to be removed, the cable will contain wires colour coded as follows: green or green and yellow: earth; blue or white: neutral; brown or black: live.
- ☞ Check that mains voltage and current conform with the equipment (see rating plate).
- ☞ Ensure that installation is in compliance with limitations from the degree of protection, see section "Technical data".
- ☞ In case of dewiness, e. g. the equipment is carried from cold environment into the operating room, allow the equipment to acclimatize.



Obey all other **relevant safety requirements** (e. g. safety at work regulations for laboratories and explosion protection guidelines).

- ☞ Ensure that the equipment is suitable for the intended application. Check that the system to be evacuated is mechanically stable and that all fittings are secure. Attention: Flexible elements tend to shrink when evacuated.

Due to the high compression ratio of the pumps, pressure at the outlet port might be generated being higher than the max. permitted pressure compatible with the mechanical stability of the system.

- ☞ Check compatibility with max. permitted pressure and pressure differences, see section "Technical data".
- ☞ Adopt suitable measures to prevent the release of hazardous, explosive and corrosive fluids.
- ☞ Adopt suitable measures to prevent any danger arising from the formation of hot surfaces or electric sparks.
- ☞ Check compatibility with max. ambient temperature and ensure adequate ventilation to fan.



Note symbol hot surfaces at the pump (according to IEC 1010 recommendation). During normal operation the diffusion pump becomes very hot, especially the vacuum connection.

- ☞ Do not touch, risk of burning!
- ☞ Avoid contacting or covering the pump with burnable material, or material which may be damaged due to high temperature, e. g. mains cable.



The equipment is to our understanding in compliance with the basic requirements of the applicable EC-directives and harmonized standards with regard to design, type and model, especially directive IEC 1010. This directive describes in detail conditions, in which the equipment can be handled in a safe status.

- ☞ Adopt suitable measures in case of differences, e. g. operating the equipment outdoors, installation in altitudes of more than 1000 m above sea level, conductive pollution or dewiness.



Do not permit any **uncontrolled pressurizing** (e. g. make sure that the exhaust pipeline cannot become blocked). If you have an exhaust-isolation valve, make sure that you cannot operate the equipment with the valve closed. **Risk of bursting!**

- ☞ Ensure that the system design does not allow the exhaust pipeline to become blocked.
- ☞ Avoid overpressure of more than 0.2 bar in case inert gas is connected.



The pumping units have no approval for operation in or for pumping of potentially explosive atmospheres.

If pumping **different substances**, purge the pumping unit with inert gas prior to changing the pumped media in order to pump out residues and to avoid reactions of the pumped substances with each other with and the pump material or pump oil. Ensure that the materials of the wetted parts are compatible with the pumped substances, see section "Technical data". If necessary change oil before before changing the pumped media.

Take into consideration interactions and chemical reactions of the pumped media.

The pumping units are **not suitable** for pumping substances which may form **deposits** inside the pump.

- ☞ If there is a danger of the formation of **deposits** or of corrosion, check oil and aggregat through the sight glass and inlet and outlet of the pump. If necessary replace corroded parts or change pump oil.



The pumping units are **not suitable** to pump **unstable substances** and substances which react explosively under **impact** (mechanical stress) and/or when being exposed to **elevated temperatures** without air.

The pumping units are **not suitable** to pump **self inflammable** substances, substances which are inflammable without air and **explosive substances**.

The pumping units are **not suitable** for pumping dust and have **no approval** for operation below ground.

- ☞ Adopt suitable measures to prevent the release of dangerous, explosive, corrosive or polluting fluids.
- ☞ Wear appropriate safety-clothing when coming in contact with contaminated components.
- ☞ Obey regulations when disposing chemicals.
- ☞ Use inert gas for venting the equipment.



Due to the **residual leak rate** of the equipment, there may be an exchange of gas, albeit extremely slight, between the environment and the vacuum system.

- ☞ Adopt suitable measures to prevent contamination of the pumped substances or the environment.

Avoid overpressure at the gas ballast valve in case of high inlet pressure due to the high compression ratio.

- ☞ Pumped gases or collected condensate may leak in case the valve is open.
- ☞ Ensure that the inlet pipeline does not become contaminated when using inert gas.



The motor of the rotary vane pump is shut down by a **thermal cutout** in the winding.

- ☞ Attention: Manual reset is necessary. Switch off the pump or isolate the equipment from mains. Wait approx. five minutes before restarting the pump.

The motor of the diffusion pump is shut down by a **safety switch** in case of excess temperature.

- ☞ Attention: After cooling down, the heating of the diffusion pump starts automatically. Adopt suitable measures if a restart is a potential source of danger.
- ☞ Failure of the pump (e. g. due to power failure) must not lead to a critical dangerous situation under any circumstances.



Attention: If the permitted inlet pressure or the backing pressure at the diffusion pump are passed over, pump fluid may enter other parts of the vacuum system.

Ensure that in case of failure the pumping unit turns always into a safe status.

- ☞ In case of leaks in the manifold of the pumping unit or at the shaft seal of the rotary vane pump pumped substances may leak in the environment, in the pump housing or the motor.
- ☞ Obey especially notes on use and operation and maintenance.



Under normal operation conditions, pump oils and lubricants are not toxic and their use entails no danger. Certain hazardous are, however, associated with some of these products. The following precautions must be adopted during use and operation in order to meet health and safety requirements.



Adopt precautionary measures (e. g. appropriate safety-clothing and protective goggles) to avoid excessive contact with the skin and possible irritations (including dermatitis).

- ☞ Do not inhale or swallow. Maintain adequate levels of hygiene and cleanliness.
- ☞ Ensure that the pump location is well ventilated and that possible toxic effects of certain vapours are avoided.
- ☞ Use suitable collecting and disposing systems if necessary.

Use **special oils** for the rotary vane pump (e. g. perfluoropolyether oils) if:

- ☞ The pump operates in the vicinity of potential ignition sources.
- ☞ Oxygen or other flammable gases account for a large proportion of the evacuated gases.



Do not allow oils to be poured into or enter the drainage system or other bodies of water.

- ☞ Spillage can cause accidents, use suitable means of removing split oil.
- ☞ Observe all relevant statutory requirements and regulations concerning the storage and disposal of oil.

Use only oil of the recommended type.

- ☞ Other oils or operating fluids may cause damage of the pump or dangers.

Use only **genuine spare parts and accessories**.

- ☞ Otherwise safety and performance of the equipment as well as the electromagnetic compatibility of the equipment might be reduced.

The A-weighted emission sound pressure level of the pump does not exceed 70 dB(A). Measurement according to EN ISO 2151:2004 and EN ISO 3744:1995 with standard silencer or exhaust tube at outlet.



Ensure that maintenance is done only by suitably trained and supervised technicians. Ensure that the maintenance technician is familiar with the safety procedures which relate to the products processed by the pumping system.

Before starting maintenance, wait two minutes after isolating the equipment from mains to allow the capacitors to discharge.

Attention: The pump might be contaminated with the process chemicals that have been pumped during operation. Ensure that the pump is decontaminated before maintenance and take adequate precautions to protect people from the effects of dangerous substances if contamination has occurred.

☞ Wear appropriate safety-clothing when you come in contact with contaminated components.

Before starting **maintenance**, vent the system, isolate the pump and other components from the vacuum system and the electrical supply so that they cannot be operated accidentally. Allow sufficient cooling of the pump. Drain condensate if necessary, avoid the release of dangerous substances.

In order to comply with law (occupational, health and safety regulations, safety at work law and regulations for environmental protection) vacuum pumps, components and measuring instruments returned to the manufacturer can be repaired only when certain procedures (see section “**Notes on return to the factory**”) are followed.

Technical data

☞ See also instructions for use for the rotary vane pump and the diffusion pump.

Type		HP 40B	HP 63B
Backing pump		RZ 2.5	RZ 6
Recommended oil for backing pump		VACUUBRAND B oil	VACUUBRAND B oil
Diffusion pump		AX 65	AX 65
Recommended pump fluid for diffusion pump		silicon oil DC 704	silicon oil DC 704
Ultimate (total) vacuum with silicon oil DC 704	mbar	$< 1 \times 10^{-6}$	$< 1 \times 10^{-6}$
Permitted ambient temperature storage	°C	-10 to +60	-10 to +60
operation	°C	+12 to +40	+12 to +40
Permitted atmospheric moisture during operation (no separation of moisture)	%	30 - 85	30 - 85
Max. permitted range of voltage supply		230V~ +/-10% / 50/60Hz	230V~ +/-10% / 50/60Hz
Rated input current 230V~ 50/60 Hz	A	2.7 / 2.2	3.2 / 3.2
Power draw 230V~ 50/60 Hz	VA	621 / 506	736 / 736
Degree of protection IEC 529		IP 10B	IP 10B
Inlet		NW 40 KF	NW 63 ISO K
Outlet		hose nozzle NW 10	hose nozzle NW 10
Overall dimensions L x W x H	mm	approx. 445 x 385 x 435	approx. 445 x 365 x 460
Mass	kg	25.4	30.9

We reserve the right for technical modification without prior notice!

- * If the pumping unit is running with fresh oil (oil has been changed or fresh oil has been added), a running time of up to two days might be necessary to achieve the ultimate vacuum. This effect is due to the normal outgassing of the oil.

HP 40B2

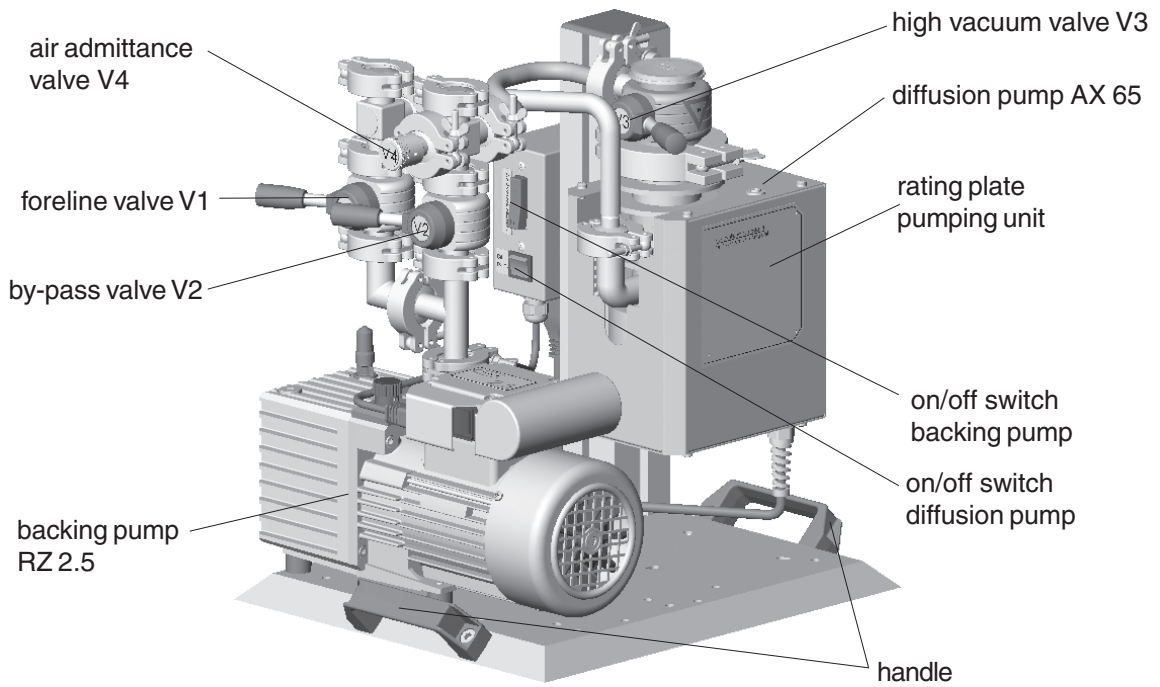

HP 63B2

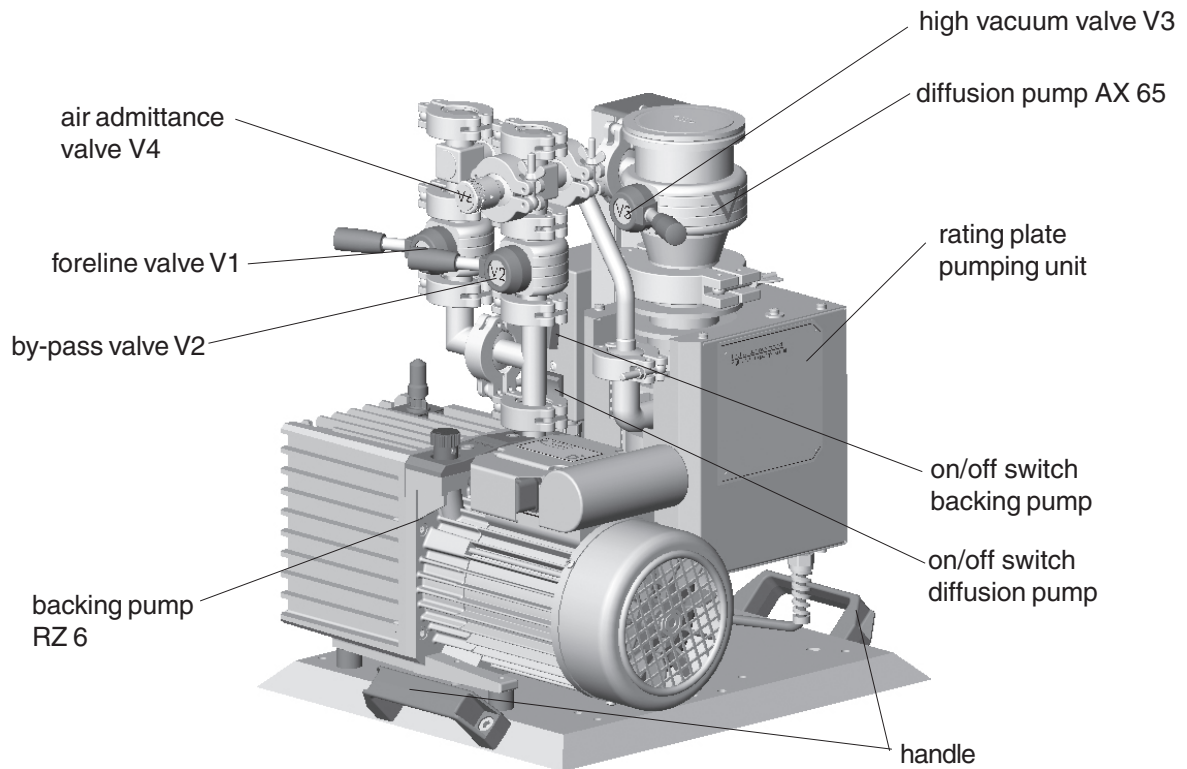

Use and operation



Installing in a vacuum system:

- ☞ Avoid throttling losses by using connecting pipes with large diameter and keep them as short as possible.
- ☞ Reduce the transmission of vibration and prevent loading due to rigid pipelines. Insert elastic hoses or flexible elements as couplings between the pump and rigid pipes. **Attention:** Flexible elements tend to shrink if evacuated.
- ☞ Use a suitable valve to isolate the pump from the vacuum system if you need to allow the pump to warm up before you pump condensable vapours or if you clean the pump before it is switched off.
- ☞ Connect the exhaust to a suitable treatment plant to prevent the discharge of dangerous gases and vapours to the surrounding atmosphere. Use a catchpot to prevent the drainage of contaminated condensate back into the pump.



Operation:

Proceed strictly according to the given order, time and pressure data.

Switching on the pumping unit (pump and vacuum vessel at atmospheric pressure)

- Open fore vacuum valve (V1), close by-pass valve (V2), high vacuum valve (V3) and venting valve (V4).
- Switch on backing pump (rotary vane pump), switch on diffusion pump.
- ☞ The diffusion pump can be switched on only if the backing pump has been switched on.
- Close foreline valve (V1) after the heating time (approx. 15 minutes) has elapsed and foreline pressure (M1) is < 0.1 mbar.
- Open by-pass valve (V2).
- Close by-pass valve (V2) at a pressure < 0.1 mbar.
- Open foreline valve (V1).
- Open high vacuum valve (V3).
- ☞ **Attention:** If the pressure in the foreline (M1) rises to 0.1 mbar, close high vacuum valve (V3) and pump down with backing pump to a pressure below 0.1 mbar.



- ☞ **If the thermostatic cutout of the backing pump has tripped it is indispensable to close the high vacuum valve (V3) and switch off the diffusion pump.**

Venting the vacuum vessel

- Close high vacuum valve (V3).
- Close by-pass valve (V2) if not closed.
- Open venting valve (V4).

Pumping down again

- Close venting valve (V4).
- Close foreline valve (V1).
- Open by-pass valve (V2).
- Close by-pass valve at a pressure < 0.1 mbar.
- Open foreline valve (V1).
- Open high vacuum valve (V3).
- ☞ **Attention:** If the pressure in the foreline (M1) rises to 0.1 mbar, close high vacuum valve (V3) and pump down with backing pump to a pressure below 0.1 mbar.



- ☞ **If the thermostatic cutout of the backing pump has tripped it is indispensable to close the high vacuum valve (V3) and switch off the diffusion pump.**



During operation:

Max. ambient temperature: **40 °C**.

- ☞ Make sure ventilation is adequate if pump is installed in a housing or if ambient temperature is elevated.
- ☞ If pump is installed in altitudes of more than 1000 m above mean sea level check compatibility with applicable safety requirements, e. g. DIN VDE 0530 (motor may overheat due to insufficient cooling).
- ☞ Check oil level in the rotary vane pump and pump fluid in the diffusion pump at appropriate intervals.



Shutdown:

For venting the vacuum vessel to atmospheric pressure, proceed as follows:

- Close high vacuum valve (V3), vent the apparatus using V 4 if necessary.
- Switch off diffusion pump.
- Keep the backing pump running for 30 - 45 minutes.
- Close fore vacuum valve (V1).
- Switch off backing pump.
- ☞ **Attention:** Never switch off backing pump together with diffusion pump.

Proceeding in accordance with the instructions given ensures that the diffusion pump is left under vacuum (no condensate built-up in the pump fluid).

To avoid the formation of condensate in the pump housing it is advisable to leave the pump or the pumping system under vacuum if possible.

If the gas ballast valve is open, a power failure may cause air admittance to the pumping unit. In case this constitutes a potential source of danger, take appropriate safety measures (e. g. install a solenoid operated gas ballast valve).

Vacuum connection diagram

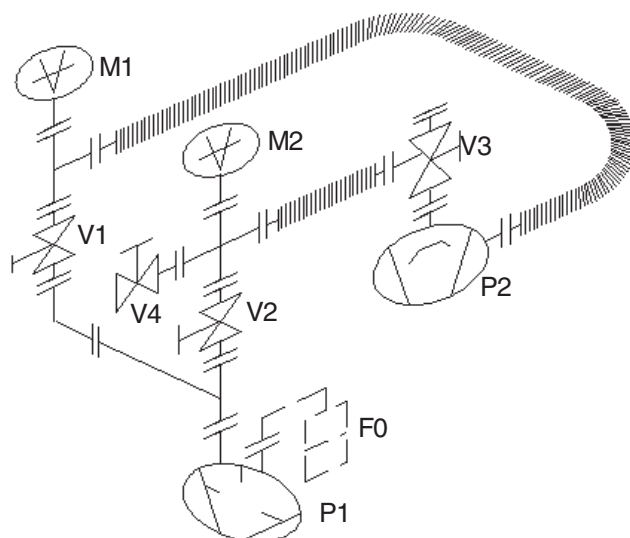

- P1 backing pump
- P2 diffusion pump
- V1 foreline valve
- V2 by-pass valve
- V3 high vacuum valve
- V4 venting valve
- M1 measuring point 1
- M2 measuring point 2
- F0 oil mist filter

Troubleshooting

☞ See instructions for use for the rotary vane pump and the diffusion pump.

Maintenance

☞ See instructions for use for the rotary vane pump and the diffusion pump.

Notes on filling the pump fluid into the diffusion pump

It is also possible to fill the pump fluid through the valve into the inlet flange of the diffusion pump.

➔ Open valve plate and fill in the pump fluid between cold cap and pump housing (approx. 30 ml).

Notes on return to the factory

Repair - return - DKD calibration



Safety and health of our staff, laws and regulations regarding the handling of dangerous goods, occupational health and safety regulations and regulations regarding safe disposal of waste require that for all pumps and other products the **"Health and safety clearance form"** must be sent to our office duly completed and signed before any equipment is dispatched to our premises.

Fax or post a completed copy of the health and safety clearance form to us in advance. The declaration must arrive before the equipment. Enclose a second completed copy with the product. If the equipment is contaminated you must notify the carrier.

No repair / DKD calibration is possible unless the correctly completed form is returned. Inevitably, there will be a delay in processing the equipment if information is missing or if this procedure is not obeyed.



If the product has come in contact with chemicals, radioactive substances or other substances dangerous to health or environment, the product must be decontaminated prior to **sending it back to the factory.**

- ☞ Return the product to us **disassembled and cleaned** and accompanied by a certificate verifying decontamination or
- ☞ Contact an industrial cleaning and **decontamination service** directly or
- ☞ Authorize us to send the product to an industrial cleaning facility **at your expense.**

To expedite repair and to reduce costs, please enclose a detailed description of the problem and the product's operating conditions with every product returned for repair. We submit **quotations** only on request and always at the customer's expense. If an order is given, the costs incurred are offset from the costs for repair or from the purchase price, if the customer prefers to buy a new product instead of repairing the defective one.

☞ **If you do not wish a repair on the basis of our quotation, the equipment might be returned to you disassembled and at your charge!**

In many cases, the **components must be cleaned in the factory** prior to repair.

For cleaning we use an environmentally responsible water based process. Unfortunately the combined attack of elevated temperature, cleaning agent, ultrasonic treatment and mechanical stress (from pressurised water) may result in damage to the paint. Please mark in the health and safety clearance form if you wish a **repaint at your expense** just in case such a damage should occur.

We also replace parts due to optical aspects upon your request.

Before returning the equipment ensure that (if applicable):

- ☞ Oil has been drained and an adequate quantity of fresh oil has been filled in to protect against corrosion.
- ☞ Equipment has been cleaned and/or decontaminated.
- ☞ All inlet and outlet ports have been sealed.
- ☞ Equipment has been properly packed, if necessary, please order an original packaging (costs will be charged), marked as appropriate and the carrier has been notified.
- ☞ Ensure that the completed health and safety declaration is enclosed.



We hope for your understanding for these measures, which are beyond our control.

Scrapping and waste disposal:

Dispose of the equipment and any components removed from it safely in accordance with all local and national safety and environmental requirements. Particular care must be taken with components and waste oil which have been contaminated with dangerous substances from the process. Do not incinerate fluoroelastomer seals and O-rings.

- ☞ You may authorize us to dispose of the equipment **at your expense.**





**Konformitätserklärung
Declaration of conformity
Déclaration de conformité**

Pumpstand / Pumping unit / Groupe de pompage

HP 40B (230V; 699029)

HP 63B (230V; 699037)

Hiermit erklären wir, dass das oben bezeichnete Gerät in Konzeption und Bauart sowie in der von uns in Verkehr gebrachten Ausführung den grundlegenden Anforderungen der zutreffenden, aufgeführten EU-Richtlinien entspricht. Bei einer mit uns nicht abgestimmten Änderung an dem Gerät verliert diese Erklärung ihre Gültigkeit.

We herewith declare that the product designated above is in compliance with the basic requirements of the applicable EC-directives stated below with regard to design, type and model sold by us. This certificate ceases to be valid if the product is modified without the agreement of the manufacturer.

Par la présente, nous déclarons que le dispositif désigné ci-dessus est conforme aux prescriptions de base des directives EU applicables et indiqués en ci que concerne conception, dessin et modèle vendu par nous-mêmes. Cette déclaration cesse d'être valable si des modifications sont apportées au dispositif sans notre autorisation préalable.

Maschinenrichtlinie (mit Änderungen) / Machine directive (with supplements) / Directive Machines (avec des suppléments)

2006/42/EG

Niederspannungsrichtlinie / Low-Voltage Directive / Directive Basse Tension

2006/95/EG

Richtlinie Elektromagnetische Verträglichkeit / Electromagnetic Compatibility Directive / Directive Compatibilité Electromagnétique

2004/108/EG

Angewandte Harmonisierte Normen / Harmonized Standards applied / Normes Harmonisées utilisées

DIN EN 12100-2, DIN EN 61010-1, DIN EN 1012-2, DIN EN 61326-1

Managementsysteme / Management systems / Systèmes de Management

EN ISO 9001, EN ISO 14001 (1997-2006)

Wertheim, 16.12.2009

.....
Ort, Datum / place, date / lieu, date

.....
(Dr. F. Gitmans)

Geschäftsführer / Managing Director / Gérant

ppa.

.....
(Dr. J. Dirscherl)

Technischer Leiter / Technical Director / Directeur technique

VACUUBRAND GMBH + CO KG

-Vakuumtechnik im System-
-Technology for Vacuum Systems-
-Technologie pour système à vide-

Alfred-Zippe-Str. 4 - 97877 Wertheim

Tel.: +49 9342 808-0 - Fax: +49 9342 808-450

E-Mail: info@vacuubrand.de

Web: www.vacuubrand.com

Disclaimer: Our technical literature is only intended to inform our customer. The validity of general empirical values and results obtained under test conditions for specific applications depend on a number of factors beyond our control. It is therefore strictly the users' responsibility to very carefully check the validity of application to their specific requirements. No claims arising from the information provided in this literature will, consequently, be entertained.

VACUUBRAND GMBH + CO KG
-Technology for Vacuum Systems-

© 2009 VACUUBRAND GMBH + CO KG Printed in Germany

Alfred-Zippe-Str. 4 - 97877 Wertheim
Tel.: +49 9342 808-0 - Fax: +49 9342 808-450
E-Mail: info@vacuubrand.de
Web: www.vacuubrand.de

