



Technology for Vacuum Systems

Instructions for use

Customized equipment MZ 2S

Attention: Please observe the notes in the supplementary sheet.

69 62 52

Notice: Customized equipment

Date: 12.11.2004

Equipment (Product): MZ 2S 230 V 50/60 Hz

Material No.: 69 62 52

Instructions for use for the standard equipment: MZ 2



The customized product identified above is based on a standard product which has been modified following the customer's requirement for modification.

Therefore, certain features of the customized product are different from those of the corresponding standard product. In general we do not have sufficient experience whether the modifications made meet the customer's requirements. It is the customer's responsibility to check the suitability of the equipment for the intended application *prior* to use.

The instructions for use of the standard product are enclosed.

It is the user's responsibility to check very carefully if specific information given in the instructions for use can be applied to the customized product.

In particular, the following differences have to be considered:

Wetted material of seals at fittings: FPM.

Diaphragm clamping disc made of ETFE (20% carbon fibre).

Component	Cat. No.
Diaphragm (PTFE)	2x 63 70 28
Valve (FFKM)	4x 63 69 72
O-ring 28 x 1,5 (FPM)	4x 63 70 90
Hose (PTFE)	-



Technology for Vacuum Systems

Instructions for use

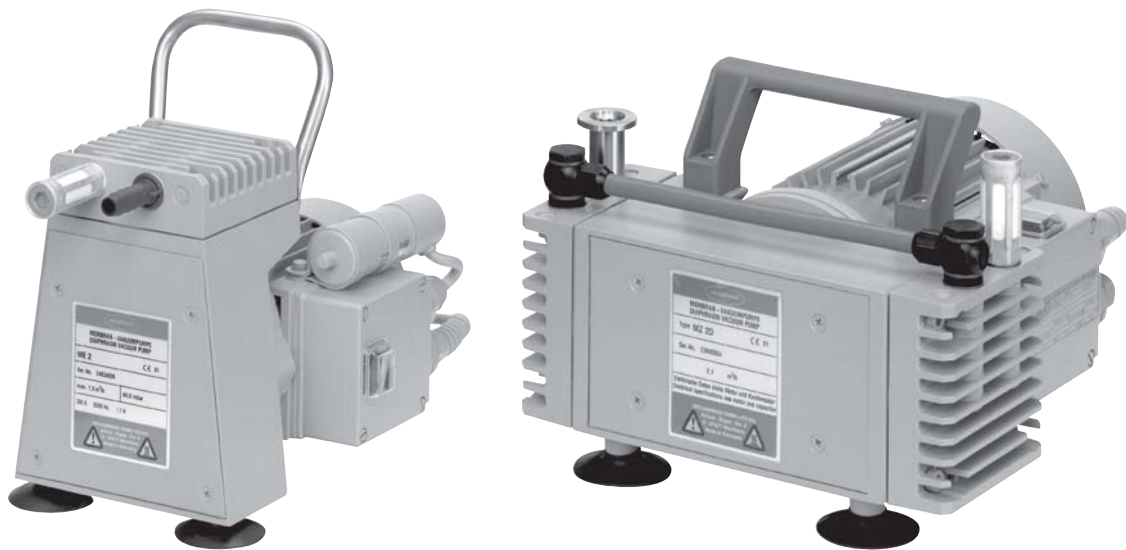

ME 2 - ME 4 - MZ 2 - MZ 2D

Diaphragm pumps

Dear customer,

Your VACUUBRAND diaphragm pump shall support you at your work for a long time without any trouble and with full load output. Thanks to our large practical experience we attained much information how you could add to an efficient application and to personal safety. Please read these instructions for use prior to the initial start-up of your pump.

VACUUBRAND diaphragm pumps are the result of many years of experience in construction and practical operation of these pumps combined with the latest results in material and manufacturing technology.

Our quality maxim is the "zero fault principle":

Every delivered diaphragm pump is tested extensively including an endurance run of 18 hours. Due to this endurance run, also faults, which occur rarely, are reported and can be corrected. Every single diaphragm pump is tested on achievement of the specification after the endurance run.

Every VACUUBRAND pump leaving our factory achieves the specification. We feel obliged to this high quality standard.

We are aware that the vacuum pump should not draw a part of the real work and we hope to contribute with our products to an effective and troublefree realisation of your work.

Yours

VACUUBRAND GMBH + CO KG

After sales service: Contact your local dealer or call (++49) 9342/808-193.

Contents

Safety information!	4
Technical data	7
Use and operation	11
Accessories - Installation	13
Troubleshooting	15
Replacing diaphragms and valves	16
Notes on return to the factory	21
Health and safety clearance form	22



Attention! Important notes!



Not permitted! Misuse may cause damage.



Caution! Hot surface!



Isolate equipment from mains.



Note.

Safety information!



Remove all packing material, remove the product from its packing-box, remove the protective covers from the inlet and outlet ports and keep, inspect the equipment. If the equipment is damaged, notify the supplier and the carrier in writing within three days; state the item number of the product together with the order number and the supplier's invoice number. Retain all packing material for inspection.

Do not use the equipment if it is damaged.

If the equipment is not used immediately, replace the protective covers. Store the equipment in suitable conditions.

- ☞ **Read and comply with this manual before installing or operating the equipment.**
- ☞ Transport the pump at the provided handles.

Use the equipment **for the intended use only** (for generation of vacuum).

- ☞ Prevent any part of the human body from coming in contact with the vacuum.
- ☞ Comply with notes on correct vacuum and electrical connections, see section "Use and operation".
- ☞ Make sure that the individual components are only connected, combined and operated according to their design and as indicated in the instructions for use.



Comply with **national safety regulations and safety requirements** concerning the use of vacuum and electrical equipment.

- ☞ Equipment must be connected only to a **suitable fused and protected electrical supply** and a suitable earth point. Failure to connect the motor to ground may result in deadly electrical shock.
- ☞ The supply cable may be fitted with a moulded European IEC plug or a plug suitable for your local electrical supply. If the plug has been removed or has to be removed, the cable will contain wires colour coded as follows: green or green and yellow: earth; blue or white: neutral; brown or black: live.

- ☞ **Check that mains voltage and current conform with the equipment (see rating plate):**



Pumps with **dual-voltage motor (100-120 V / 200-230 V; 50/60 Hz):**

- ☞ The equipment must be connected to a **suitable fused and protected electrical supply** and a suitable earth point only, provide slow-blow fuse according to voltage supply (see "Technical data").
- ☞ Check that the voltage changeover switch is positioned correctly.

Attention: If the pump is switched on with the voltage not correctly selected, the motor may be damaged!

- ☞ If the equipment is brought from cold environment into a room for operation, allow the equipment to warm up (pay attention to **water condensation on** cold surfaces).
- ☞ Make sure ventilation is adequate if pump is installed in a housing or if ambient temperature is elevated.



Comply with all **relevant safety requirements** (regulations and guidelines) and adopt suitable safety measures.

- ☞ Provide a firm level platform for the equipment and check that the system to be evacuated is mechanically stable and that all fittings are secure.

Attention: Flexible elements tend to shrink when evacuated.

Due to the high compression ratio of the pumps, pressure at the outlet port might be generated being higher than the max. permitted pressure compatible with the mechanical stability of the system.

- ☞ Comply with **maximum permitted pressures** and pressure differences, see section "Technical data". Do not operate the pump with overpressure at the inlet.



Do not permit any **uncontrolled pressurizing** (e. g. make sure that the exhaust pipeline cannot become blocked). If you have an exhaust-isolation valve, make sure that you cannot operate the equipment with the valve closed. **Risk of bursting!**

- ☞ Ensure that the system design does not allow the exhaust pipeline to become blocked.
- ☞ Avoid overpressure of more than 0.2 bar in case inert gas is connected.
- ☞ The diameter of the inlet and outlet pipeline should be at the least as large as the diameter of the pump connection pipelines.



To the best of our knowledge the equipment is in compliance with the requirements of the applicable EC-directives and harmonized standards (see "Declaration of conformity") with regard to design, type and model, especially directive IEC 1010. This directive gives in detail conditions, under which the equipment can be operated safely (see also IP degree of protection).

- ☞ Adopt suitable measures in case of differences, e. g. using the equipment outdoors, installation in altitudes of more than 1000 m above mean sea level, conductive pollution or dewiness.



Pay attention to symbol "hot surfaces" on the equipment (according to IEC 1010 recommendation).

- ☞ Adopt suitable measures to prevent any danger arising from the formation of hot surfaces or electric sparks.



The pumps have no approval for operation in or for pumping of potentially explosive atmospheres.

If pumping **different substances**, purge the pump with inert gas prior to changing the pumped media in order to pump out residues and to avoid reactions of the pumped substances with each other with and the pump material. Ensure that the materials of the wetted parts are compatible with the pumped substances, see section "Technical data".

Take into consideration interactions and chemical reactions of the pumped media.

The pumps are **not suitable** for pumping substances which may form **deposits** inside the pump.

- ☞ If there is a danger of the formation of **deposits** in the pump chamber (check inlet and outlet of the pump) inspect the pump chamber regularly and clean if necessary. The pumps are **not suitable** to pump **unstable substances** and substances which react explosively under **impact** (mechanical stress) and/or when being exposed to **elevated temperatures** without air.

The pumps are **not suitable** to pump **self inflammable** substances, substances which are inflammable without air and **explosive substances**.

The pumps are **not suitable** for pumping dust and have **no approval** for operation below ground.



Ensure that the materials of the wetted parts are compatible with the pumped substances, see section "Technical data".

- ☞ Adopt suitable measures to prevent the release of dangerous, explosive, corrosive or polluting fluids.
- ☞ Use inert gas for gas ballast or venting if necessary.
- ☞ The user must take suitable precautions to prevent any formation of explosive mixtures in the expansion chamber or at the outlet. In case of a diaphragm crack, mechanically generated sparks, hot surfaces or static electricity may ignite these mixtures.
- ☞ Take adequate precautions to protect people from the effects of dangerous substances (chemicals, thermal decomposition products of fluoroelastomers), wear appropriate safety-clothing and safety glasses.
- ☞ Comply with applicable regulations when disposing of chemicals. Take into consideration that chemicals may be polluted.



Due to the residual **leak rate of the equipment**, there may be an exchange of gas, albeit extremely slight, between the environment and the vacuum system.

- ☞ Adopt suitable measures to prevent contamination of the pumped substances or the environment.



The motor is shut down by a **thermal cutout** in the winding.

- ☞ Attention: Manual reset is necessary. Switch off the pump or isolate the equipment from mains. Wait approx. five minutes before restarting the pump.
- ☞ **Attention:** In case of **supply voltage below 100V**, the lock of the cutout might be restricted and the pump might restart on its own after sufficient cooling down. Take suitable precautions, if an automatic restart of the pump may lead to a critical dangerous situation.
- ☞ Avoid high heat supply (e. g. due to hot process gases).
- ☞ Ensure sufficient air admittance if pump is installed in a housing.

Ensure that in case of failure the pump and the vacuum system always will turn into a safe status.

- ☞ In case of diaphragm cracks or leaks in the manifold pumped substances might be released into the environment or into the pump housing. To reduce the risk of leaks, ask for a diaphragm pump with additional safety diaphragm.
- ☞ Comply especially with notes on operation and use and maintenance.



Use only **genuine spare parts and accessories**.

- ☞ Otherwise safety and performance of the equipment as well as the electromagnetic compatibility of the equipment might be reduced. Possibly the CE mark or the C/US conformity becomes void if not using genuine spare parts.

Ensure that maintenance is done only by suitably trained and supervised technicians. Ensure that the maintenance technician is familiar with the safety procedures which relate to the product processed by the vacuum system and that the equipment, if necessary, is appropriately decontaminated before starting maintenance.

Comply with local and national safety regulations.

Wear parts have to be replaced regularly. In case of normal wear the lifetime of the diaphragms and valves is > 10000 operating hours. Bearings have a typical durability of 40000 h. Motor capacitors have a typical durability in the range of 10000 to 40000 h depending strongly on the operation conditions like ambient temperature, humidity or load.

- ☞ Check every capacitor regularly by measuring its capacity and estimating its operation time. Exchange old capacitors early enough to prevent a failure. If an overaged motor capacitor fails it might get hot and even melt and may cause a flame to form which could be **dangerous for persons and equipment in the vicinity**. The capacitors have to be replaced by an electrician.



Before starting **maintenance** vent the system, isolate the pump and other components from the vacuum system and the electrical supply, drain condensate and allow sufficient cooling of the pump.

Before starting maintenance, wait **two minutes** after isolating the equipment from mains to allow the capacitors to discharge.

In order to comply with law (occupational, health and safety regulations, safety at work law and regulations for environmental protection) vacuum pumps, components and measuring instruments returned to the manufacturer can be repaired only when certain procedures (see section "**Notes on return to the factory**") are followed.

Technical data

Type		ME 2	ME 4	MZ 2	MZ 2D
Pumping speed 50/60 Hz DIN 28432	m ³ /h	1.9/2.2 maximum	3.6/4.0 maximum	1.9/2.2	2.2/2.4
Ultimate (total) vacuum (absolute) DIN 28432	mbar	< 80	< 80	9	4
Max. permitted outlet pressure (absolute)	bar	2	4	2	1.1
Max. permitted difference pressure between inlet and outlet	bar	2	2	2	1.1
Max. permitted ambient temperature during storage / operation		-10 to +60 / +10 to +40			
Max. permitted relative atmospheric moisture during operation (no separation of condensat)		30 to 85			
Motor power	W	120	180	180	180
Motor protection		thermal cutout			
Rated current draw					
100 V~ 50/60 Hz	A	-	-	3.6/3.8	-
120 V~ 60 Hz	A	-	3.0	3.0	3.0
230 V~ 50/60 Hz	A	1.1/1.1	1.4/1.6	1.4/1.6	1.4/1.6
100-120/200-230 V~ 50 Hz	A	2.6/1.3*	-	-	3.6/1.7*
100-120/200-230 V~ 60 Hz	A	2.6/1.3*	-	-	3.8/1.8*
Max. permitted range of supply voltage Pay attention to motor rating plate!		100 V~ +/-10% 50/60 Hz 120 V~ +5%/-10% 60 Hz 230 V~ +/-10% 50/60 Hz 100-120 V~ +5%/-10% 50/60 Hz* 200-230 V~ +/-10% 50/60 Hz*			
Degree of protection IEC 529		IP 54 IP 40*	IP 54 -	IP 54 -	IP 54 IP 40*
Rated speed 50/60 Hz	min ⁻¹	1500/1800	1500/1800	1500/1800	1500/1800
Inlet		hose nozzle DN 10 G 1/4"			small flange DN 16
Outlet		silencer			
Overall dimensions L x W x H	mm	275 x 164 x 249 300 x 164 x 249*	266 x 235 x 175 -	266 x 235 x 164 -	266 x 235 x 164 162 x 265 x 171*
Mass	kg	6.3 7.5*	10.1 -	10.1 -	10.5 10.4*

* Pump with dual-voltage motor (100-120/200-230 V 50/60 Hz)

We reserve the right for technical modification without prior notice!

Components	Wetted parts
housing cover / head cover	aluminium alloy (AlSi12)
diaphragm clamping disc	aluminium alloy (AlSi12)
diaphragm / valve	FPM
hose nozzle (ME 2 / MZ 2)	PBT
hose nozzle (ME 4)	stainless steel
small flange (MZ 2D)	stainless steel
silencer	PA / PE
hose	PE
fitting	aluminium, anodized
seal (ME 2 / ME 4 / MZ 2)	PVC
seal (MZ 2D)	FPM

We reserve the right for technical modification without prior notice!

Gas inlet temperatures:

Operating condition	Inlet pressure	Permitted range of gas temperatures at inlet
Continuous operation	> 100 mbar (high gas load)	➡ +10°C to +40°C
Continuous operation	< 100 mbar (low gas load)	➡ 0°C to +60°C
Short-time operation (< 5 minutes)	< 100 mbar (low gas load)	➡ -10°C to +80°C

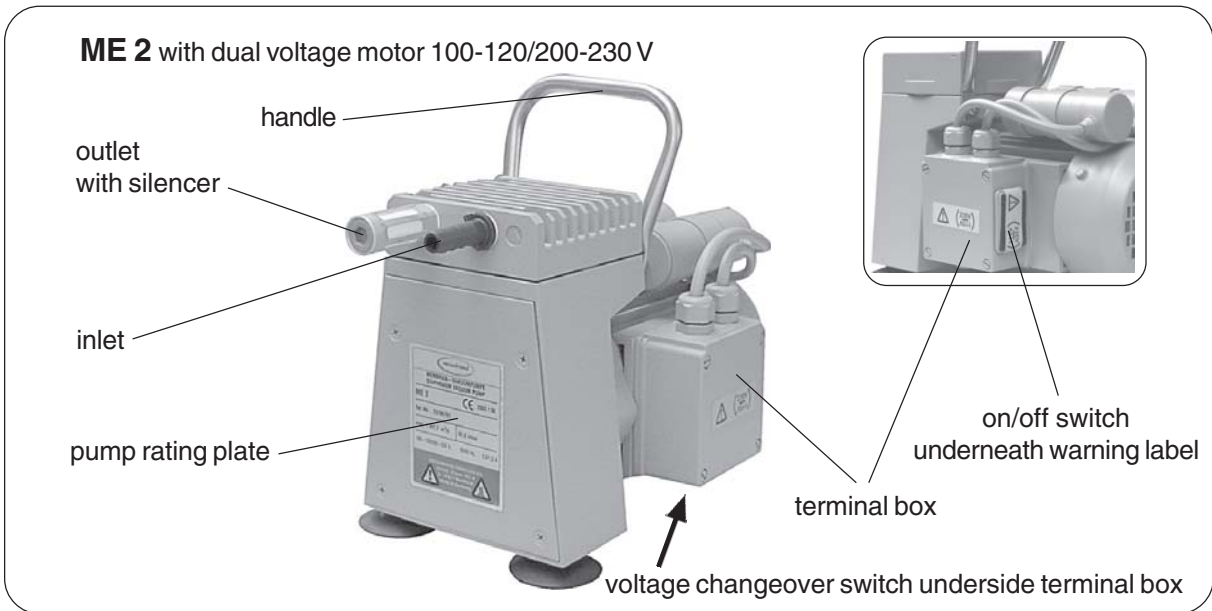
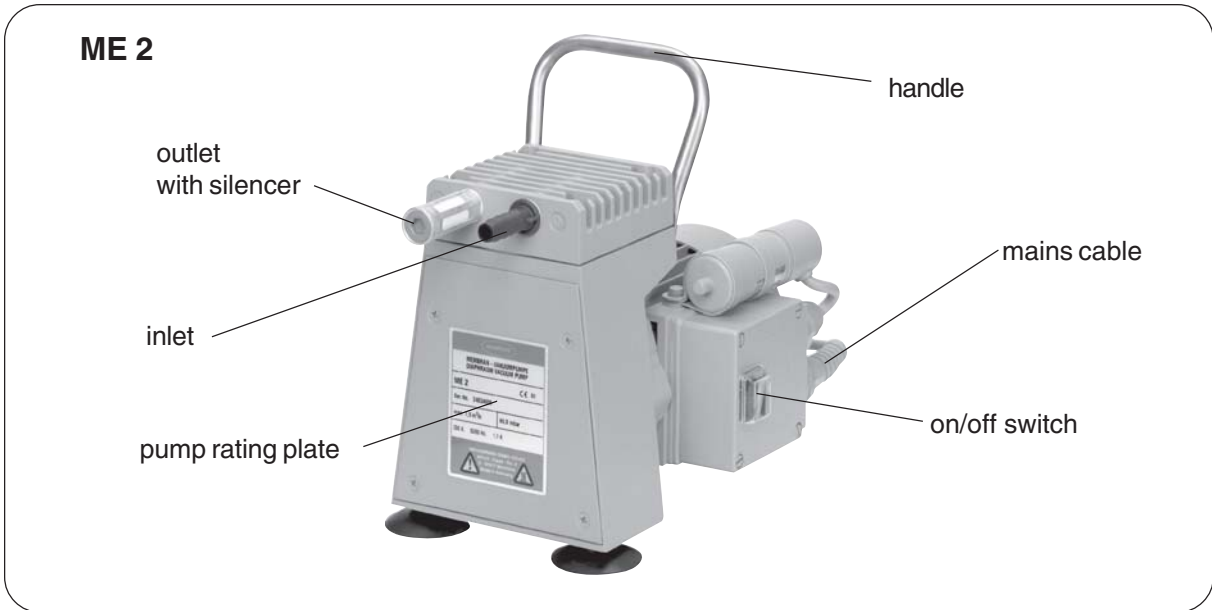

ME 4



MZ 2 / MZ 2D (fig.: MZ 2D)



MZ 2D with dual-voltage motor 100-120/200-230 V

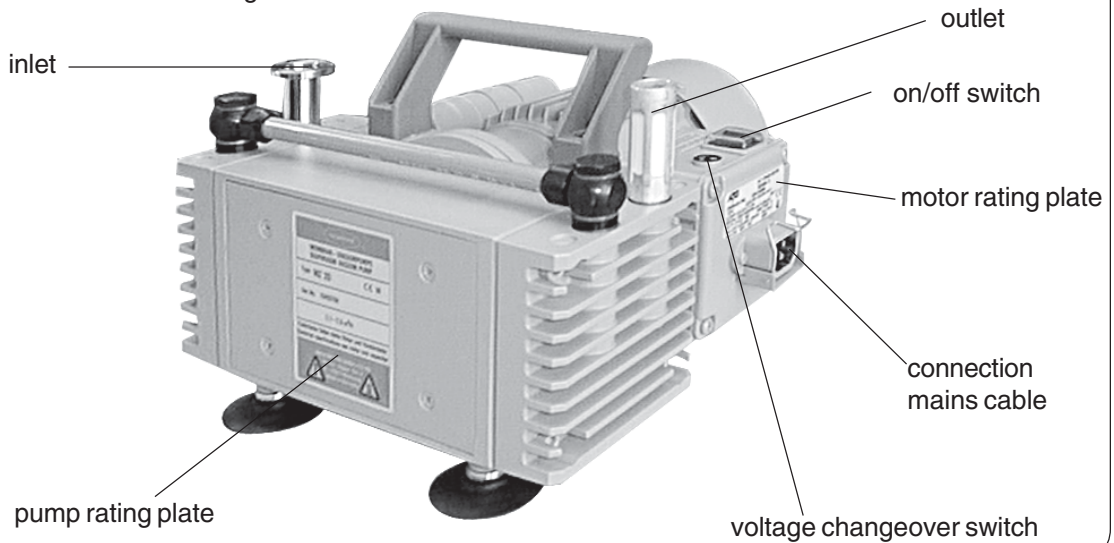

Use and operation



Installing in a vacuum system:

- Avoid throttling losses by using connecting pipes with large diameter and keep them as short as possible.
 - Reduce the transmission of vibration and prevent loading due to rigid pipelines. Insert elastic hoses or flexible elements as couplings between the pump and rigid pipes.
 - Use a suitable valve to isolate the pump from the vacuum system if you need to allow the pump to warm up before you pump condensable vapours or if you clean the pump before it is switched off.
 - Connect the exhaust to a suitable treatment plant to prevent the discharge of dangerous gases and vapours to the surrounding atmosphere. Use a catchpot to prevent the drainage of contaminated condensate back into the pump.
- **Before switching on the pump check that mains voltage and current conform with the equipment!**



Pump with dual-voltage motor:

- **Check that the voltage changeover switch at the terminal box is positioned correctly.**

Attention: If the pump is switched on with the voltage not correctly selected, the motor may be damaged! Pay attention to the warning label on the on/off switch (ME 2 only) and remove after having set the voltage changeover switch to the correct position!

Selecting the supply voltage:



Attention:
Before starting the pump, check that the voltage changeover switch at the terminal box is correctly positioned. Change the selection at the voltage changeover switch only if the pump is separated from mains.

Voltage changeover switch:

Use a screw driver to adjust the supply voltage on the **voltage changeover switch** at the terminal box of the pump:

"115" corresponds to 100-120V and
"230" corresponds to 200-230V.



ME 2 with dual-voltage motor



MZ 2D with dual voltage motor



During operation:

Max. ambient temperature: 40 °C

- ☞ Make sure ventilation is adequate if pump is installed in a housing or if ambient temperature is elevated.
- ☞ If pump is installed in altitudes of more than 1000 m above mean sea level check compatibility with applicable safety requirements, e. g. IEC 60034 (motor may over-heat due to insufficient cooling).



The motor is shut down by a **thermal cutout** in the winding.

- ☞ Attention: Manual reset is necessary. Switch off the pump or isolate the equipment from mains. Wait approx. five minutes before restarting the pump.
- ☞ **Attention:** In case of **supply voltage below 100V**, the lock of the cutout might be restricted and the pump might restart on its own after sufficient cooling down. Take suitable precautions, if an automatic restart of the pump may lead to a critical dangerous situation.



Due to the high compression ratio of the pumps, pressure at the outlet port might be generated being higher than the max. permitted pressure compatible with the mechanical stability of the system.

Do not start pump if **pressure difference between inlet and outlet port exceeds max. 1 bar**. Attempts to start pump at higher difference may cause blockade and damage of the motor.

- ☞ Check compatibility with **max. permitted pressure at outlet** and **max. pressure difference between inlet and outlet ports**.

Prevent internal condensation, transfer of liquids or dust. The diaphragm and valves will be damaged, if liquids are pumped in significant amounts.

A warm up period (approx. 15 min.) is required to ensure that the rated ultimate total pressure and pumping speed are attained.

Shutdown:

Has the pump been exposed to condensate?

- ☞ Allow the pump to continue to run at atmospheric pressure for a few minutes.

Has the pump been exposed to media which may damage the pump materials or form deposits?

- ☞ Check and clean pump heads if necessary.



Accessories - Installation

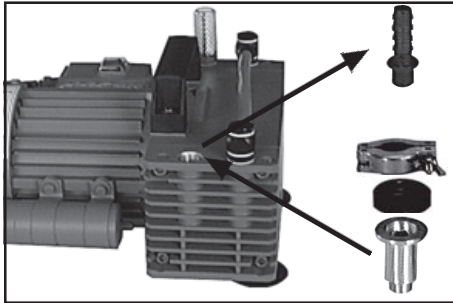

ME 2 / MZ 2

Small flange DN 16	66 25 90
Clamping ring DN 10/16 (aluminium)	66 00 00
Centring ring DN 10/16 (NBR)	66 01 90
Hose nozzle (for MZ 2D)	63 97 58

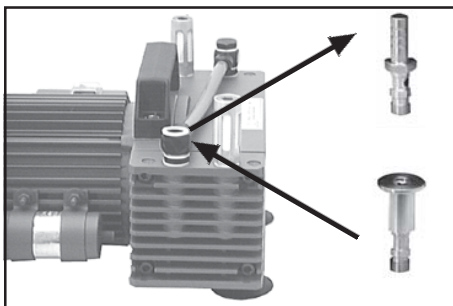

ME 4

Small flange DN 16	63 98 61
Clamping ring DN 10/16 (aluminium)	66 00 00
Centring ring DN 10/16 (NBR)	66 01 90

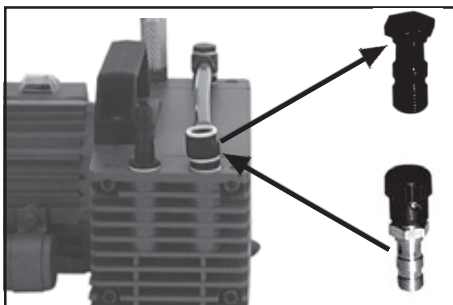

Gas ballast valve	68 58 12
--------------------------------	-----------------

(Note seal rings when assembling.)



Digital vacuum gauge DVR 2	68 29 02
---	-----------------

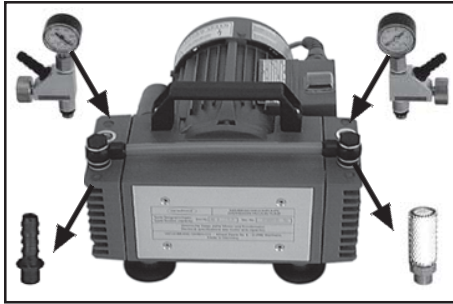

Vacuum adjustment device (inlet) 69 68 40
Pressure adjustment device (outlet) 69 68 41

Installation vacuum and / or pressure adjustment device at ME 2 / MZ 2

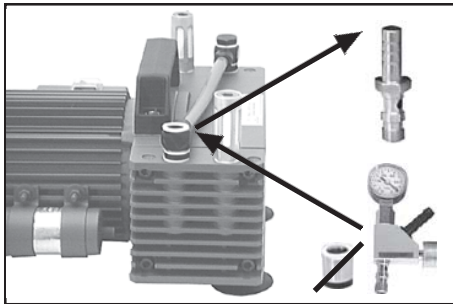

Installation vacuum adjustment device at ME 4
 (omit extra parts)



Installation pressure adjustment device at ME 4
 (use extra seal rings of the pressure adjustment device)

Additional parts are necessary:

Swivelling screw-in fitting **63 85 48**
 Ring type nipple **63 81 97**
 Hose (PE), 185 mm **63 98 61**
 Ring nut **3 12 03 48**

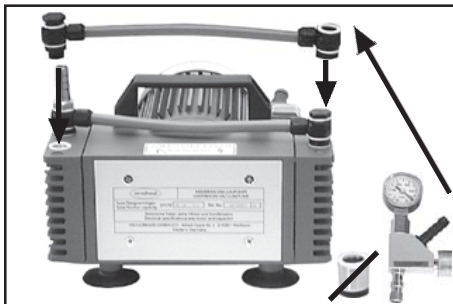

Assemble control valve first, then align and fasten gauge.



Troubleshooting

Fault	Possible cause	Remedy
<input type="checkbox"/> Pump fails to start or stops immediately.	<ul style="list-style-type: none"> ➔ Mains not plugged in, electrical supply failure? ➔ Pressure in outlet pipeline too high? ➔ Motor overloaded? ➔ Voltage changeover switch not correctly positioned? 	<ul style="list-style-type: none"> ☞ Plug in. Check fuse. ☞ Remove blockade in line, open valve. ☞ Allow motor to cool, identify and eliminate cause of failure. Manual reset necessary. Switch off pump or isolate equipment from mains. ☞ Set the voltage changeover switch to the position being conform with the supply voltage.
<input type="checkbox"/> Pump does not achieve ultimate total pressure or normal pumping speed.	<ul style="list-style-type: none"> ➔ Centering ring not correctly positioned or leak in the pipeline or vacuum system? ➔ Long narrow line? ➔ Pump has been exposed to condensate? ➔ Deposits have been formed inside the pump? ➔ Valves or diaphragm damaged? ➔ Outgasing substances or vapour generated in the process? 	<ul style="list-style-type: none"> ☞ Check pump with a vacuum gauge directly at pump inlet port, check connections and line. ☞ Use line with larger diameter, length as short as possible. ☞ Run pump at atmospheric pressure for a few minutes. ☞ Clean and inspect pump heads. ☞ Replace valves and/or diaphragms. ☞ Check process parameters.
<input type="checkbox"/> Pump too noisy.	<ul style="list-style-type: none"> ➔ Atmospheric or high pressure at inlet port? ➔ Diaphragm clamping disc loose? ➔ None of above mentioned causes? 	<ul style="list-style-type: none"> ☞ Connect hose to pump outlet. ☞ Perform maintenance. ☞ Contact local distributor.
<input type="checkbox"/> Pump seized.		<ul style="list-style-type: none"> ☞ Contact local distributor.



A service manual with exploded view drawings, spare parts list and directions for repair is available on request.

☞ The service manual is for trained service people.

Replacing diaphragms and valves



All bearings are encapsulated and are filled with long-life lubricant. Under normal operating conditions, the pump is maintenance free. The valves and the diaphragms as well as the motor capacitors are wear parts. If the rated ultimate vacuum is no longer achieved or in case of increased noise level, the pump interior, the diaphragms and the valves must be cleaned and the diaphragms and valves must be checked for cracks or other damage.

Depending on individual cases it may be efficient to check and clean the pump heads on a regular basis. In case of normal wear the lifetime of the diaphragms and valves is > 10000 operating hours.

☞ Prevent internal condensation, transfer of liquids or dust. The diaphragm and valves will be damaged, if liquids are pumped in significant amount.

If the pump is exposed to corrosive gases or vapour or in case of deposits, maintenance should be carried out frequently.

☞ Regular maintenance will improve the lifetime of the pump and also protect both man and environment.



Before starting maintenance vent the system, isolate the pump and other components from the vacuum system and the electrical supply. Drain condensate if applicable, avoid the release of pollutants. Allow sufficient cooling of the pump. **Ensure that the pump cannot be operated accidentally. Never operate the pump if covers or other parts of the pump are disassembled. Never operate a defective or damaged pump.**

Ensure that the maintenance technician is familiar with the safety procedures which relate to the products processed by the pumping system.

The pump might be contaminated with the process chemicals that have been pumped during operation. Ensure that the pump is decontaminated before maintenance and take adequate precautions to protect people from the effects of dangerous substances if contamination has occurred.

☞ Wear appropriate safety-clothing when you come in contact with contaminated components.



Set of seals (diaphragm, valves) for ME 2	69 68 10
Set of seals (diaphragms, valves) for ME 4 / MZ 2	69 68 11
Set of seals (diaphragms, valves) for MZ 2D	69 68 35
O-ring (FPM) 48 x 3 (head cover of MZ 2D)	3 12 05 44
O-ring (FPM) 28 x 1,5 (head cover of MZ 2D)	63 70 90

☞ **Please read section "Replacing diaphragms and valves" completely before starting maintenance.**

Partially the pictures show pumps in other versions. This doesn't influence replacing diaphragms and valves of the pump.



Tools:

- Phillips screw driver size 2
- Open-ended wrench w/f 17
- Hex key size 5
- Face wrench with torque indicator
(Fig. VACUUBRAND face wrench, cat. no.: 63 75 80)

Cleaning and inspecting the pump heads:

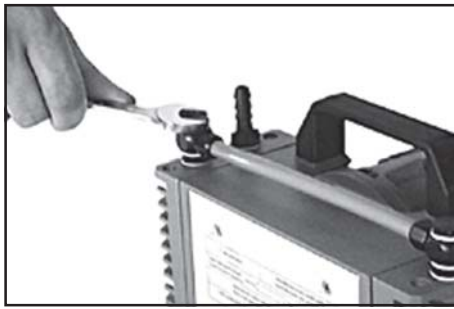

- ➔ Use open-ended wrench, remove the screw-in fittings together with the hose from all pump heads.

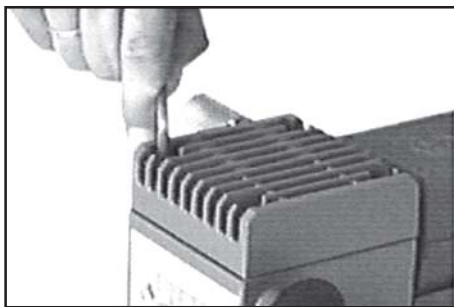

- ➔ To check the valves use hex key to remove four socket-head screws from pump head and remove housing cover with head cover, valves and O-ring (MD 4 / MV 2 only).
- ⚠ Never remove parts by using a spiky or sharp-edged tool (e.g. screw driver), we recommend to use a rubber mallet or compressed air (to be blown **carefully** into port).
- ➔ Remove head cover carefully from housing cover. Note position of valves and remove them.
- ⚠ Replace valves if necessary.
- ⚠ Use petroleum ether or industrial solvent to remove deposits. Do not inhale.

View of the disassembled pump head parts with different technical design

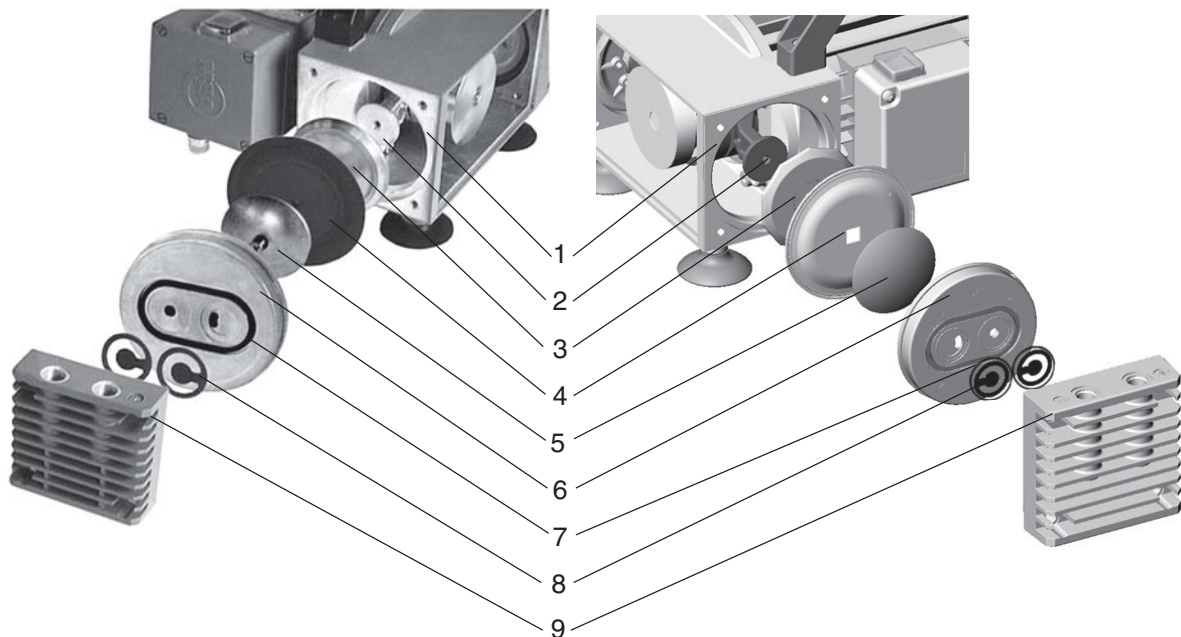

diaphragm with round hole;
clamping disc with countersunk head screw

diaphragm with square hole;
clamping disc with square head screw

1 housing
2 rod
3 diaphragm support disc

4 diaphragm
5 diaphragm clamping disc
6 head cover

7 seal ring (only MZ 2D)
8 valve
9 housing cover

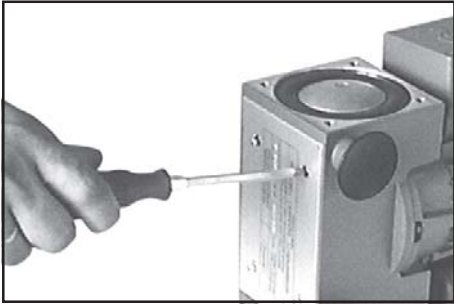

- ☞ Check diaphragm for damage and replace if necessary.
- ➔ To do so use Phillips screw driver to remove four countersunk head screws and lift off housing plate with rating plate.
- ☞ Use petroleum ether or industrial solvent to remove deposits if necessary. Do not inhale.

Notes regarding the assembling of the diaphragm

! The set of seals is designated for diaphragm pumps with different technical performance. Delivering pumps with square hole diaphragm starts in the second term of 2002, but not at the same time for all types of pumps. **(Exception MZ 2D: Always diaphragm with round hole.)**
 Replacing a **diaphragm with round hole**, use the delivered diaphragm completely.
 Replacing a **diaphragm with square hole**, remove the punched part in the centre of the diaphragm before assembling.

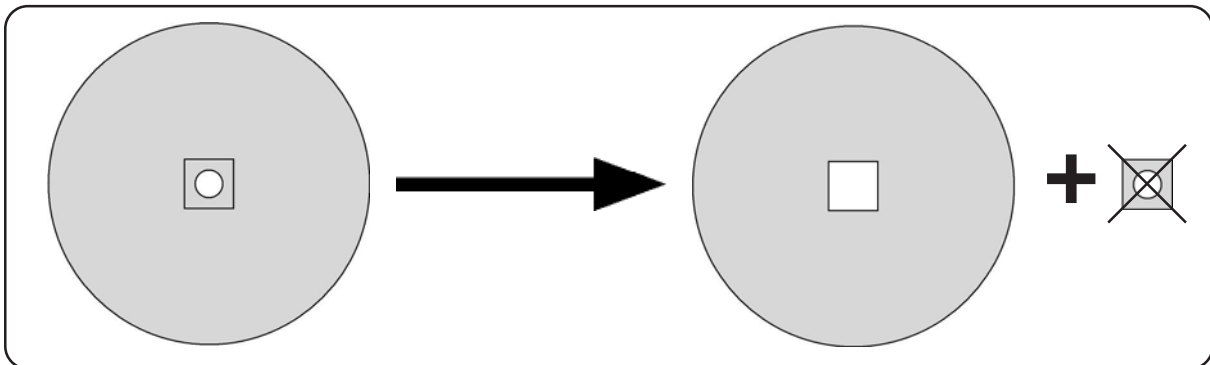

Replacing a diaphragm with round hole



- ➔ Use Phillips screw driver, remove countersunk head screw in the centre of the diaphragm clamping disc.
- ☞ **Note:** Screw is secured by adhesive to prevent it from being detached. Clean screw or use new one (cat. no.: 63 98 47).
- ☞ If the old diaphragm is difficult to separate from the support disc, immerse assembly in naphtha or petroleum ether. Do not inhale!

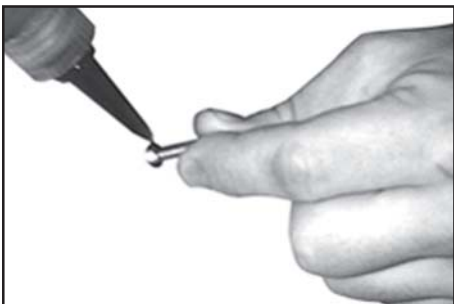

- ➔ Check for washers. Do not mix the washers from the different heads. Make sure that the original number is reassembled at the individual pump head.
- ☞ Smaller number of washers: The pump will not attain ultimate vacuum. More washers: Clamping disc will hit head cover; noise or even blockade of the pump.
- ➔ Insert diaphragm support disc and new diaphragm.
- Note:** Double diaphragm.
- ➔ Insert diaphragm clamping disc, apply a drop of adhesive (OmniFit® 50M or Loctite® 243) to lower side of screw head and thread and screw diaphragm clamping disc, diaphragm and diaphragm support disc to connecting rod.

OmniFit® and Loctite® are registered trade marks of Henkel Technologies

Replacing a diaphragm with square hole

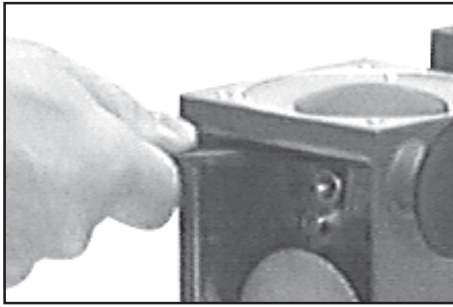

- ➔ Use a face wrench to remove diaphragm support disc.
- ➔ Check for washers under clamping disc. Do not mix the washers from the different heads. Make sure that the original number is reassembled at the individual pump head.
- ⚠ Smaller number of washers: The pump will not attain ultimate vacuum. More washers: Clamping disc will hit head cover; noise or even blockade of the pump.



- ➔ Position new diaphragm between diaphragm clamping disc with square head screw and diaphragm support disc.
- ⚠ **Note:** Double diaphragm.

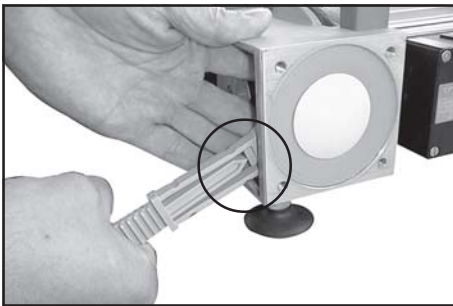

- ➔ **Use the face wrench with torque indicator** to assemble diaphragm clamping disc, diaphragm and diaphragm support disc (and eventually washers) to the connecting rod.
 - ⚠ Make sure that the square head screw of the diaphragm clamping disc is correctly seated in the guide hole of the diaphragm support disc.
- Optimum torque for the diaphragm support disc: **6 Nm**.
- ⚠ The optimum torque is achieved if the pointer in the handle of the VACUUBRAND face wrench shows to the longer marking line.

Assembling pump heads:

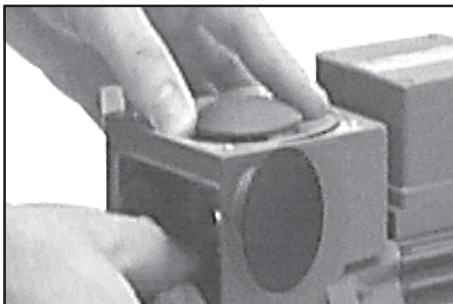

- ➔ By turning eccentric bushing (front of connecting rod), bring connecting rod into a position in which diaphragm is in contact with housing and centred with respect to bore.

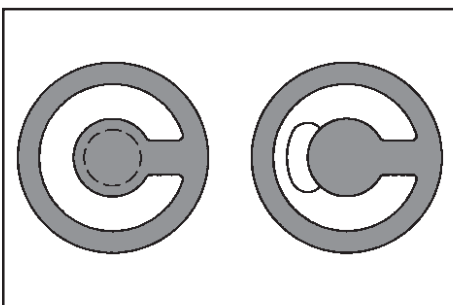

- Reassemble in reverse order.
- ➔ Install head cover (with O-ring if applicable), valves and housing cover.
 - ⚠ Make sure that the **valves are correctly seated**: Valves at the outlet with round centred opening under valve, valves at the inlet with kidney-shaped opening beside valve.
 - ➔ By turning eccentric bushing, bring connecting rod into upper turning point position (Max. stroke of the rod).
 - ⚠ Pay attention that the diaphragm stays positioned centrally so that it will become clamped uniformly between housing and head cover.

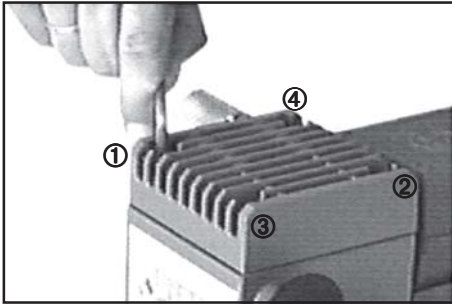

- ⚠ **Attention: When reassembling the housing covers of pumps type MZ 2D ensure that the head covers are not exchanged. Always assemble the housing cover with groove at the outlet side of the pump.**
- ➔ Screw in four socket head screws fixing housing cover cross-wise (e. g. in the sequence ①, ②, ③, ④) first slightly, then tighten.
- ⚠ Do not tighten until head cover is in contact with housing, torque **12 Nm**.

Individual performance check of a pump head :



- By measuring the pressure at the inlet port of the individual head:
- Use a suitable vacuum gauge (e. g. DVR 2, cat. no.: 68 29 02), make sure that it is correctly calibrated, and measure the pressure at the inlet port. A vacuum of less than 85 mbar should be indicated.
- ⚠ If the reading is higher, recheck the pump chamber and make sure that the valves and the diaphragms are correctly seated (diaphragms concentric with bore).

Assembling fittings:



- ➔ Use open-ended wrench to assemble fittings with connection hoses to all pump heads.



If the pump does not achieve the ultimate pressure:

- ⚠ In case the diaphragms and valves have been replaced, a run-in period of several hours is required before the pump achieves its ultimate vacuum.

If all pump heads achieve a vacuum below 85 mbar but pump does not achieve the ultimate total pressure:

Check hose connectors between pump heads and manifolds for leaks. If necessary recheck pump chamber.

Notes on return to the factory

Repair - return - DKD calibration



Safety and health of our staff, laws and regulations regarding the handling of dangerous goods, occupational health and safety regulations and regulations regarding safe disposal of waste require that for all pumps and other products the **"Health and safety clearance form"**.

must be send to our office duly completed and signed before any equipment is dispatched to our premises.

Fax or post a completed copy of the health and safety clearance form to us in advance. The declaration must arrive before the equipment. Enclose a second completed copy with the product. If the equipment is contaminated you must notify the carrier.

No repair / DKD calibration is possible unless the correctly completed form is returned. Inevitably, there will be a delay in processing the equipment if information is missing or if this procedure is not obeyed.

If the product has come in contact with chemicals, radioactive substances or other substances dangerous to health or environment, the product must be decontaminated prior to **sending it back to the factory.**

- ☞ Return the product to us **disassembled and cleaned** and accompanied by a certificate verifying decontamination or
- ☞ Contact an industrial cleaning and **decontamination service** directly or
- ☞ Authorize us to send the product to an industrial cleaning facility **at your expense.**



To expedite repair and to reduce costs, please enclose a detailed description of the problem and the product's operating conditions with every product returned for repair. We submit **quotations** only on request and always at the customer's expense. If an order is given, the costs incurred are offset from the costs for repair or from the purchase price, if the customer prefers to buy a new product instead of repairing the defective one.

☞ **If you do not wish a repair on the basis of our quotation, the equipment might be returned to you disassembled and at your charge!**

In many cases, the **components must be cleaned in the factory** prior to repair.

For cleaning we use an environmentally responsible water based process. Unfortunately the combined attack of elevated temperature, cleaning agent, ultrasonic treatment and mechanical stress (from pressurised water) may result in damage to the paint. Please mark in the health and safety clearance form if you wish a **repaint at your expense** just in case such a damage should occur.

We also replace parts due to optical aspects upon your request.

Before returning the equipment ensure that (if applicable):

- ☞ Oil has been drained and an adequate quantity of fresh oil has been filled in to protect against corrosion.
- ☞ Equipment has been cleaned and/or decontaminated.
- ☞ All inlet and outlet ports have been sealed.
- ☞ Equipment has been properly packed, if necessary, please order an original packaging (costs will be charged), marked as appropriate and the carrier has been notified.
- ☞ Ensure that the completed health and safety declaration is enclosed.



We hope for your understanding for these measures, which are beyond our control.

Scrapping and waste disposal:

Dispose of the equipment and any components removed from it safely in accordance with all local and national safety and environmental requirements. Particular care must be taken with components and waste oil which have been contaminated with dangerous substances from the process. Do not incinerate fluoroelastomer seals and "O" rings.

- ☞ You may authorize us to dispose of the equipment **at your expense.**



Health and safety clearance form

Declaration concerning safety, potential hazards and safe disposal of waste, e. g. used oil.

Safety and health of our staff, laws and regulations regarding the handling of dangerous goods, occupational health and safety regulations, safety at work laws and regulations regarding safe disposal of waste, e. g. waste oil, require that for all pumps and other products this form must be send to our office duly completed and signed before any equipment is dispatched to our premises. **Products will not be accepted for any procedure and handling and repair / DKD calibration will not start before we have received this declaration.**

- a) Fax or post a **completed copy of this form** to us in advance. The declaration must arrive before the equipment. **Enclose a second, completed copy with the product.** If the product is contaminated you must notify the carrier (**GGVE, GGVS, RID, ADR**).
- b) Inevitably, the repair process will be delayed considerably, if this information is missing or this procedure is not obeyed. We hope for your understanding for these measures which are beyond our control and that you will assist us in expediting the repair procedure.
- c) **Make sure that you know all about the substances which have been in contact with the equipment and that all questions have been answered correctly and in detail.**

<p>1. Product (Model):</p> <p>2. Serial No.:</p> <p>3. List of substances in contact with the equipment or reaction products:</p> <p>3.1 Chemical/substance name, chemical symbol:</p> <p>a)</p> <p>b)</p> <p>c)</p> <p>d)</p> <p>3.2 Important informations and precautions, e. g. danger classification:</p> <p>a)</p> <p>b)</p> <p>c)</p> <p>d)</p> <p>4. Declaration (please mark as applicable):</p> <p><input type="checkbox"/> 4.1 for non dangerous goods:</p> <p>We assure for the returned product that</p> <ul style="list-style-type: none"> - neither toxic, corrosive, biologically active, explosive, radioactive nor contamination dangerous in any way has occurred. - the product is free of dangerous substances. - the oil or residues of pumped media have been drained. <p><input type="checkbox"/> 4.2 for dangerous goods:</p> <p>We assure for the returned product that</p> <ul style="list-style-type: none"> - all substances, toxic, corrosive, biologically active, explosive, radioactive or dangerous in any way which have pumped or been in contact with the product are listed in 3.1, that the information is complete and that we have not withheld any information. - the product, in accordance with regulations, has been <ul style="list-style-type: none"> <input type="checkbox"/> cleaned <input type="checkbox"/> decontaminated <input type="checkbox"/> sterilized. 	<p>5. Way of transport / carrier:</p> <p>.....</p> <p>Day of dispatch to VACUUBRAND:</p> <p>.....</p> <p>If the paint is damaged, we wish a repaint or a replacement of parts due to optical aspects at our expense (see "Notes on return to the factory"):</p> <p><input type="checkbox"/> yes <input type="checkbox"/> no</p> <p>We declare that the following measures - where applicable - have been taken:</p> <ul style="list-style-type: none"> - The oil has been drained from the product. Important: Dispose of according to national regulations. - The interior of the product has been cleaned. - All inlet and outlet ports of the product have been sealed. - The product has been properly packed, if necessary, please order an original packaging (costs will be charged) and marked as appropriate. - The carrier has been informed about the hazardous nature of the goods (if applicable). <p>We assure VACUUBRAND that we accept liability for any damage caused by providing incomplete or incorrect information and that we shall indemnify VACUUBRAND from any claims as regards damages from third parties.</p> <p>We are aware that as expressed in § 823 BGB (Public Law Code of Germany) we are directly liable for injuries or damages suffered by third parties, particularly VACUUBRAND employees occupied with handling/repairing the product.</p> <p>Signature:</p> <p>Name (print):</p> <p>Job title (print):</p> <p>Company's seal:</p> <p>Date:</p>
---	---





**Konformitätserklärung
Declaration of conformity
Déclaration de conformité**

Membranpumpe / Diaphragm pump / Pompe à membrane

**ME 2 (69 61 20, 69 61 26) 230V
ME 4 (69 61 40, 69 61 46) 230V
MZ 2 (69 62 40, 69 62 47) 230V
MZ 2D (69 62 58, 69 62 68) 230V**

Hiermit erklären wir, daß das oben bezeichnete Gerät in Konzeption und Bauart sowie in der von uns in Verkehr gebrachten Ausführung den grundlegenden Anforderungen der zutreffenden, aufgeführten EU-Richtlinien entspricht. Bei einer mit uns nicht abgestimmten Änderung an dem Gerät verliert diese Erklärung ihre Gültigkeit.

We herewith declare that the product designated above is in compliance with the basic requirements of the applicable EC-directives stated below with regard to design, type and model sold by us. This certificate ceases to be valid if the product is modified without the agreement of the manufacturer.

Par la présente, nous déclarons que le dispositif désigné ci-dessus est conforme aux prescriptions de base des directives EU applicables et indiqués en ci que concerne conception, dessin et modèle vendu par nous-mêmes. Cette déclaration cesse d'être valable si des modifications sont apportées au dispositif sans notre autorisation préalable.

Maschinenrichtlinie (mit Änderungen) / Machine directive (with supplements) / Directive Machines (avec des suppléments)

98/37/EG

Niederspannungsrichtlinie / Low-Voltage Directive / Directive Basse Tension

2006/95/EG

Richtlinie Elektromagnetische Verträglichkeit / Electromagnetic Compatibility Directive / Directive Compatibilité Electromagnétique

89/336/EWG, 92/31/EWG, 93/68/EWG

Angewandte Harmonisierte Normen / Harmonized Standards applied / Normes Harmonisées utilisées

DIN EN 12100-2, DIN EN 61010-1, DIN EN 1012-2, DIN EN 61326

Managementsysteme / Management systems / Systèmes de Management

EN ISO 9001, EN ISO 14001 (1997-2006)

Wertheim, 20.03.2007

.....
Ort, Datum / place, date / lieu, date

.....
(Dr. R. Lachenmann)

Geschäftsführer / Managing director / Gérant

VACUUBRAND GMBH + CO KG
-Vakuumtechnik im System-
-Technology for Vacuum Systems-
-Technologie pour système à vide-

D-97866 Wertheim
Postfach / P. O. Box / B. P. 1664
D-97877 Wertheim
Alfred-Zippe-Str. 4



Dr. Bu

Disclaimer: Our technical literature is only intended to inform our customer. The validity of general empirical values and results obtained under test conditions for specific applications depend on a number of factors beyond our control. It is therefore strictly the users' responsibility to very carefully check the validity of application to their specific requirements. No claims arising from the information provided in this literature will, consequently, be entertained.

VACUUBRAND GMBH + CO KG
-Technology for Vacuum Systems-

© 2007 VACUUBRAND GMBH + CO KG Printed in Germany

Alfred-Zippe-Str. 4 - 97877 Wertheim
Tel.: +49 9342 808-0 - Fax: +49 9342 808-450
E-Mail: info@vacuubrand.de
Web: www.vacuubrand.de

