



Technology for Vacuum Systems

Instructions for use



ME 1
ME 1C
MZ 1C

Diaphragm pumps

Dear customer,

Your VACUUBRAND diaphragm pumps are designed to provide you with many years of trouble-free service with optimal performance. Our many years of practical experience allow us to provide a wealth of application and safety information. Please read these instructions for use before the initial operation of your pump.

VACUUBRAND diaphragm pumps combine our many years of experience in design, construction and practical operation, with the latest developments in material and manufacturing technology.

Our quality maxim is the "zero defect" principle:

Every diaphragm pump, before leaving our factory, is tested intensively, including an endurance run of 18 hours. Any faults, even those which occur rarely, are identified and can be eliminated immediately.

After completion of the endurance run, every pump is tested, and must achieve specifications before shipment.

We are committed to providing our customers only pumps that meet this high quality standard.

While our pumps cannot eliminate all of your work, we design, manufacture and test them to ensure that they will be an effective and trouble-free tool to assist you in that work.

Yours,

VACUUBRAND GMBH + CO KG

After sales service:

Contact your local dealer or call +49 9342 808-5500.

Trademark index:

VACUU•LAN® (US-Reg.No 3,704,401), VACUU•BUS®, VACUU•CONTROL™, chemistry-HYBRID™, Peltronic®, TURBO•MODE™, VARIO® (US-Reg.No 3,833,788), VARIO-SP™, VACUUBRAND® (US-Reg.No 3,733,388) and also the shown company logos are trademarks of VACUUBRAND GMBH + CO KG in Germany and/or other countries.

DE

Achtung: Die vorliegende Betriebsanleitung ist nicht in allen EU-Sprachen verfügbar. Der Anwender darf die beschriebenen Geräte nur dann in Betrieb nehmen, wenn er die vorliegende Anleitung versteht oder eine fachlich korrekte Übersetzung der vollständigen Anleitung vorliegen hat. Die Betriebsanleitung muss vor Inbetriebnahme der Geräte vollständig gelesen und verstanden werden, und alle geforderten Maßnahmen müssen eingehalten werden.  "Sicherheitshinweise für Vakuumgeräte"

EN

Attention: This manual is not available in all languages of the EU. The user must not operate the device if he does not understand this manual. In this case a technically correct translation of the complete manual has to be available. The manual must be completely read and understood before operation of the device and all required measures must be applied.  "Safety instructions for vacuum equipment"

FR

Attention: Le mode d'emploi présent n'est pas disponible dans toutes les langues d'Union Européenne. L'utilisateur ne doit mettre le dispositif en marche que s'il comprend le mode d'emploi présent ou si une traduction complète et correcte du mode d'emploi est sous ses yeux. Le dispositif ne doit pas être mis en marche avant que le mode d'emploi ait été lu et compris complètement et seulement si le mode d'emploi est observé et tous les mesures demandées sont prises.

 «Avis de sécurité pour des dispositifs à vide»

BG

Внимание: Тези инструкции не са преведени на всички езици от ЕО. Потребителят не бива да работи с уреда, ако не разбира инструкциите за ползване. В този случай е необходимо да бъде предоставен пълен технически превод на инструкциите за ползване. Преди работа с уреда е задължително потребителят да прочете изцяло инструкциите за работа.

 "Указания за безопасност за вакуумни уреди"

CN

注意：该操作手册不提供所有的语言版本。操作者在没有理解手册之前，不能操作该设备。在这种情况下，需要有一个整个操作手册技术上正确的翻译。在操作该设备前，必须完全阅读并理解该操作手册，必须实施所有需要的测量。

 真空设备的安全信息

CZ

Upozornění :Tento návod k použití není k dispozici ve všech jazycích Evropské unie. Uživatel není oprávněn požit přístroj pokud nerozumí tomuto návodu. V takovém případě je nutno zajistit technicky korektní překlad manuálu do češtiny. Návod musí být uživatelem prostudován a uživatel mu musí plně porozumět před tím než začne přístroj používat. Uživatel musí dodržet všechna příslušná a požadovaná opatření.  "Bezpečnostní upozornění pro vakuové přístroje".

DA

Bemærk: Denne manual foreligger ikke på alle EU sprog. Brugeren må ikke betjene apparatet hvis manualen ikke er forstået. I det tilfælde skal en teknisk korrekt oversættelse af hele manual stilles til rådighed. Manual skal være gennemlæst og forstået før apparatet betjenes og alle nødvendige forholdsregler skal tages.

 »Sikkerhedsregler for vakuumdstyr«

EE

Tähelepanu! Käesolev kasutusjuhend ei ole kõigis EL keeltes saadaval. Kasutaja ei tohi seadet käsitseda, kui ta ei saa kasutusjuhendist aru. Sel juhul peab saadaval olema kogu kasutusjuhendi tehniliselt korrektne tõlge. Enne seadme kasutamist tuleb kogu juhend läbi lugeda, see peab olema arusaadav ning kõik nõutud meetmed peavad olema rakendatud.  "Ohutusnõuded vaakumseadmetele"

ES

Atención: Este manual no está disponible en todos los idiomas de UE. El usuario no debe manejar el instrumento si no entiende este manual. En este caso se debe disponer de una traducción técnicamente correcta del manual completo. El manual debe ser leído y entendido completamente y deben aplicarse todas las medidas de seguridad antes de manejar el instrumento.  "Notas sobre la seguridad para equipos de vacío"

FI

Huomio: Tämä käyttöohje ei ole saatavilla kaikilla EU: n kielillä. Käyttäjä ei saa käyttää laitetta, jos hän ei ymmärrä tätä ohjekirjaa. Tässä tapauksessa on saatavilla oltava teknisesti oikein tehty ja täydellinen ohjekirjan käännös. Ennen laitteen käyttöä on ohjekirja luettava ja ymmärrettävä kokonaan sekä suoritettava kaikki tarvittavat valmistelut ja muut toimenpiteet.  "Vakuumlaitteen turvallisuustiedot"

GR

Προσοχή! : Οι οδηγίες αυτές δεν είναι διαθέσιμες σε όλες τις γλώσσες της Ευρωπαϊκής Ένωσης. Ο χρήστης δεν πρέπει να θέσει σε λειτουργία την συσκευή αν δεν κατανοήσει πλήρως τις οδηγίες αυτές. Σε τέτοια περίπτωση ο χρήστης πρέπει να προμηθευτεί ακριβή μετάφραση του βιβλίου οδηγιών. Ο χρήστης πρέπει να διαβάσει και να κατανοήσει πλήρως τις οδηγίες χρήσης και να λάβει όλα τα απαραίτητα μέτρα πριν θέσει σε λειτουργία την συσκευή.  "Υποδείξεις ασφάλειας για αντλίες κενού"

HR

Pažnja: ove upute ne postoje na svim jezicima Europske Unije. Korisnik nemora raditi sa aparatom ako ne razumije ove upute. U tom slučaju tehnicki ispravni prijevod cijelih uputstava mora biti na raspolaganju. Uputstva moraju biti cijela procitana i razumljiva prije rada sa aparatom i sve zahtijevane mjere moraju biti primjenjene.

 "Sigurnosne napomene za vakuumske uređaje"

HU

Figyelem! Ez a kezelési utasítás nem áll rendelkezésre az EU összes nyelvén. Ha a felhasználó nem érti jelen használati utasítás szövegét, nem üzemeltetheti a készüléket. Ez esetben a teljes gépkönyv fordításáról gondoskodni kell. Üzembe helyezés előtt a kezelőnek végig kell olvasnia, meg kell értenie azt, továbbá az üzemeltetéshez szükséges összes mérést el kell végeznie.  "A vákuum-készülékekkel kapcsolatos biztonsági tudnivalók"

IT

Attenzione: Questo manuale non è disponibile in tutte le lingue della Comunità Europea (CE). L'utilizzatore non deve operare con lo strumento se non comprende questo manuale. In questo caso deve essere resa disponibile una traduzione tecnicamente corretta del manuale completo. Il manuale deve essere completamente letto e compreso prima di operare con lo strumento e devono essere applicati tutti gli accorgimenti richiesti.  "Istruzioni di sicurezza per apparecchi a vuoto"

JP

注意：この取扱説明書はすべての言語で利用可能ではありません。もしこの取扱説明書を理解できないならば、ユーザーは装置を操作してはなりません。この場合、技術的に正しい翻訳がなされた完全なマニュアルを用意しなければなりません。装置を作動する前にマニュアルを完全に読み、そして理解されなくてはなりません。そして、すべての要求される対策を講じなければなりません。

 真空装置を安全に取り扱うために

KR

주의: 이 매뉴얼은 모든 언어로 번역되지 않습니다. 만약 이 매뉴얼의 내용을 충분히 인지하지 못했다면 기기를 작동하지 마십시오. 매뉴얼의 내용을 기술적으로 정확하게 번역한 경우에 이용하십시오. 기기를 사용하기 전에 이 매뉴얼을 충분히 읽고 이해하고 모든 요구되는 사항들을 적용해야 합니다.

 진공 장비에 대한 안전 정보

LT

Dėmesio: šis vadovas nėra pateikiamas visomis ES kalbomis. Naudotojui draudžiama eksploatuoti įtaisą, jeigu jis nesupranta šio vadovo. Tokiu atveju reikia turėti viso vadovo techniškai taisyklingą vertimą. Vadovą būtina visą perskaityti ir suprasti pateikiamas instrukcijas prieš pradėdant eksploatuoti įtaisą, bei imtis visų reikiamų priemonių.  "Vakuuminės įrangos saugos informacija"

LV

Uzmanību: Lietotāja instrukcija nav pieejama visās ES valodās. Lietotājs nedrīkst lietot iekārtu, ja viņš nesaprot lietotāja instrukcijā rakstīto. Šādā gadījumā, ir nepieciešams nodrošināt tehniski pareizu visas lietotāja instrukcijas tulkojumu. Pirms sākt lietot iekārtu, un, lai izpildītu visas nepieciešamās prasības, iekārtas lietotāja instrukcija ir pilnībā jāizlasa un jāsaprot.  "Vakuuma iekārtu drošības noteikumi"

NL

Attentie: Deze gebruiksaanwijzing is niet in alle talen van de EU verkrijgbaar. De gebruiker moet niet met dit apparaat gaan werken als voor hem/haar de gebruiksaanwijzing niet voldoende duidelijk is. Bij gebruik van deze apparatuur is het noodzakelijk een technisch correcte vertaling van de complete gebruiksaanwijzing te hebben. Voor het in gebruik nemen van het apparaat moet de gebruiksaanwijzing volledig gelezen en duidelijk zijn en dienen alle benodigde maatregelen te zijn genomen.  "Veiligheidsvoorschriften voor vacuümapparaten"

PL

Uwaga!! Ta instrukcja nie jest dostępna we wszystkich językach Unii Europejskiej. Użytkownik nie może rozpocząć pracy z urządzeniem dopóki nie przeczytał instrukcji i nie jest pewien wszystkich informacji w niej zawartych. Instrukcja musi być w całości przeczytana i zrozumiana przed podjęciem pracy z urządzeniem oraz należy podjąć wszystkie niezbędne kroki związane z prawidłowym użytkowaniem.

 "Wskazówki bezpieczeństwa do urządzeń próżniowych"

PT

Atenção: Este manual não está disponível em todas as línguas da UE. O usuário não deve utilizar o dispositivo, se não entender este manual. Neste caso, uma tradução tecnicamente correta do manual completo tem de estar disponível. O manual deve ser lido e entendido completamente antes da utilização do equipamento e todas as medidas necessárias devem ser aplicadas.  "Informação de Segurança para Equipamento que funciona a Vácuo"

RO

Atentie: Acest manual nu este disponibil in toate limbile EU. Utilizatorul nu trebuie sa lucreze cu aparatul daca nu intelege manualul. Astfel, va fi disponibile o traducere corecta si completa a manualului. Manualul trebuie citit si inteles in intregime inainte de a lucra cu aparatul si a luat toate masurile care se impun.

 "Instrucțiuni de siguranță pentru aparatele de vidare"

RU

Внимание: Эта инструкция по эксплуатации не имеется на всех языках. Потребителю не дозволено эксплуатировать данный прибор, если он не понимает эту инструкцию. В этом случае нужен технически правильный перевод полной инструкции. Прежде чем использовать этот прибор, необходимо полностью прочитать и понять эту инструкцию и принять все необходимые меры.  "Указания по технике безопасности при работе с вакуумными устройствами"

SE

Varning: Denna instruktion är inte tillgänglig på alla språk inom EU. Användaren får inte starta utrustningen om hon/han inte förstår denna instruktion. Om så är fallet måste en tekniskt korrekt instruktion göras tillgänglig. Instruktionen måste läsas och förstås helt före utrustningen tas i drift och nödvändiga åtgärder göres.

 "Säkerhetsinformation för vakuumutrustning"

SI

Pozor: Ta navodila niso na voljo v vseh jezikih EU. Uporabnik ne sme upravljati z napravo, če ne razume teh navodil. V primeru nerazumljivosti mora biti na voljo tehnično pravilen prevod. Navodila se morajo prebrati in razumeti pred uporaba naprave, opravljene pa moraja biti tudi vse potrebne meritve.

 "Varnostni nasveti za vakuumske naprave"

SK

Upozornenie: Tento manuál nie je k dispozícii vo všetkých jazykoch EÚ. Užívateľ nesmie obsluhovať zariadenie, pokiaľ nerozumie tomuto manuálu. V takomto prípade musí byť k dispozícii technicky správny preklad celého manuálu. Pred obsluhou zariadenia je potrebné si prečítať celý manuál a porozumieť mu, a musia byť prijaté všetky opatrenia.  "Bezpečnostné pokyny pre vákuové zariadenia"

TR

Dikkat : Bu kullanım kitabı, tüm dillerde mevcut değildir. Kullanıcı, bu kullanım kitabını anlayamadıysa cihazı çalıştırmamalıdır. Bu durumda, komple kullanım kitabının, teknik olarak düzgün çevirisinin bulunması gerekir. Cihazın çalıştırılmasından önce kullanım kitabının komple okunması ve anlaşılması ve tüm gerekli ölçümlerin uygulanması gerekir.  "Vakumlu cihazlar için güvenlik uyarıları"

Contents

Safety information!	9
Important information!	9
General information	11
Intended use.....	11
Setting up and installing the equipment	12
Ambient conditions	14
Operating conditions	15
Safety during operation	17
Maintenance and repair.....	19
⚠ Important information: Equipment marking (ATEX)	22
Technical data	24
General technical data valid for all pumps	24
Gas inlet temperatures	24
Wetted parts	27
Abbreviations.....	27
Pump parts	27
Use and operation	30
Installing a pump in a vacuum system	30
During operation.....	32
Important notes regarding the use of gas ballast	33
Shutdown & storage.....	34
Accessories	35
Troubleshooting	36
Replacing diaphragms and valves	38
Cleaning and inspecting the pump heads	40
Replacing the diaphragm	44
Assembling the pump head.....	45
Replacing the fuse.....	48
Notes on return to the factory	50
Warranty	53
Health and safety clearance form	54
EC Declaration of Conformity of the Machinery	55

Safety information!

Important information!

! WARNING

- ☞ Keep this manual complete and accessible to personnel at all times!
- ☞ Read this manual carefully before installing or operating the equipment. Observe the instructions contained in this manual.
- ☞ Do not modify the equipment without authorization.

NOTICE

This manual is an integral part of the equipment described therein. It describes the safe and proper use of the vacuum pump.

Make operating personnel aware of dangers arising from the pump and the pumped substances.

VACUUBRAND disclaims any liability for inappropriate use of these pumps and for damage from failure to follow instructions contained in this manual.

This manual is only to be used and distributed in its complete and original form. It is strictly the users' responsibility to check carefully the validity of this manual with respect to his product.

Manual-no.: 999241 / 07/13/2012

The following signal word panels and safety symbols are used throughout this manual:



This is the safety alert symbol. It is used to alert you to potential personal injury hazards. Obey all safety messages that follow this symbol to avoid possible injury and death.



➔ DANGER indicates a hazardous situation which, if not avoided, will result in death or serious injury.



☞ WARNING indicates a hazardous situation which, if not avoided, could result in death or serious injury.



• CAUTION indicates a hazardous situation which, if not avoided, could result in minor or moderate injury.



NOTICE is used to address practices not related to personal injury.



Caution! Hot surface!



Disconnect equipment from AC power.

Formatting used in this manual:

Note: The signal word panels in all sections of this manual always refer to all paragraphs of the same format (➔ / ☞ / • / plain text) following each signal word panel.

The document "Safety information for vacuum equipment" is part of this manual! Read the "Safety information for vacuum equipment" and observe the instructions contained therein!

General information

NOTICE

Remove all packing material from the packing box. Remove the product from its packing-box and retain all packaging until the equipment is inspected and tested. Remove the protective caps from the inlet and outlet ports and retain for future use. Inspect the equipment promptly and carefully.

If the equipment is damaged, notify the supplier and the carrier in writing within three days. Retain all packing material for inspection. State the item number of the product together with the order number and the supplier's invoice number. Failure to check and give notice of damage will void any and all warranty claims for those deficiencies.

Replace the protective caps, if the equipment is not used immediately. Store the equipment in dry and non-corrosive conditions (see also "Technical data", pg. 24).

WARNING

☞ **Do not use any damaged equipment.**

Intended use

WARNING

☞ Do not use the pump or any system parts on humans or animals.

☞ Prevent any part of the human body from coming into contact with vacuum.

☞ Ensure that the individual components are only connected, combined and operated according to their design and as indicated in the instructions for use.

☞ Comply with all notes on correct vacuum and electrical connections; see section "Use and operation", pg. 30.

☞ Do not use the pump to generate pressure.

☞ The pumps are designed for **ambient temperatures** during operation between +50°F and +104°F (+10°C and +40°C). Periodically check maximum temperatures if installing the pump in a cabinet or a housing. Make

sure ventilation is adequate to maintain recommended operating temperature. Install an external automatic ventilation system if necessary. If pumping hot process gases, make sure that the maximum permitted gas inlet temperature is not exceeded. The maximum permitted gas inlet temperature depends on several parameters like inlet pressure and ambient temperature (see “Technical data”, pg. 24).

- ☞ Do not aspirate particles and dust.
- ☞ Do not pump liquids.

CAUTION

- Ensure that the pump is chemically resistant to the pumped substances prior to operation.

NOTICE

Use the equipment **only as intended**, that is, for generation of vacuum in vessels designed for that purpose. Any other use will automatically invalidate all warranty and liability claims. Remain aware of safety and risks.

Setting up and installing the equipment

DANGER

- ➔ Equipment must be connected only to a **suitable electrical supply** and a suitable ground point. As such, the plug must be plugged into an outlet that is properly grounded. Failure to connect the motor to ground may result in deadly electrical shock.

The supply cable may be fitted with a molded European IEC plug or a plug suitable for your local electrical supply. The cable contains wires color coded as follows: green or green and yellow: ground; blue or white: neutral; brown or black: hot.

WARNING

- ☞ Due to the high compression ratio, the pump may generate overpressure at the outlet. Check pressure compatibility with system components (e.g., exhaust tubing or exhaust valve) at the outlet.
- ☞ Do not permit any **uncontrolled pressurizing**. Make sure that the exhaust tubing cannot become blocked. If

there is an exhaust isolation valve, make sure that you cannot operate the equipment with the valve closed to avoid a **risk of bursting!**

- ☞ Always provide a free and pressureless exhaust outlet to avoid damage to pump valves and risk of bursting.
- ☞ Keep the electrical power cord away from heated surfaces.

! CAUTION

- Provide a firm, level platform for the equipment. Check that the system which you are going to evacuate is mechanically stable. Check that all fittings are secure. Ensure a stable position of the pump without any mechanical contact other than the pump feet.
- Comply with **maximum permissible pressures** at inlet and outlet and with **maximum permissible pressure differences** between inlet and outlet. See section “Technical data”, pg. 24. Do not operate the pump with overpressure at the inlet.
- Avoid overpressure of more than 17.5 psi absolute (1.2 bar absolute) in the event that gas or inert gas is connected to the pump, to the gas ballast, or to a venting valve.
- **Note:** Flexible elements will shrink when evacuated.
- Ensure that no liquids can flow on or into the pump motor when assembling or disassembling vacuum lines at the pump. Risk of corrosion and/or short circuit!
- Connect hoses gas tight at inlet and outlet of the pump.
- Ensure that no foreign objects can be drawn into the pump.
- Check the power source and the pump’s rating plate to be sure that the power source and the equipment match in voltage, phase, and frequency.
- On pumps with a dual-voltage motor, check that the voltage selection switch is set correctly. Do not change

the setting of the voltage selection switch while the pump is connected to AC power. Unplug the pump before setting the voltage selection switch. **Note:** If the pump is switched on with wrong voltage selection, the motor may be damaged!

NOTICE

Keep a minimum distance of 8 in (20 cm) between the cooling fan and surrounding items (e.g., housing, walls, etc.). Check fan regularly for dust/dirt. Clean fan guard grill if necessary to avoid a reduction of ventilation.

Use only hoses at the inlet and outlet of the pump with an inner diameter at least as large as the diameter of the pump's fittings (to avoid overpressure at the outlet, and reduction of pumping speed at the inlet).

Allow the equipment to equilibrate to ambient temperature if you bring it from cold environment into a room prior to operation. Notice if there is water condensation on cold surfaces.

Comply with all **applicable and relevant safety requirements** (regulations and guidelines). **Implement the required actions and adopt suitable safety measures.**

Ambient conditions

DANGER

➔ Do not reach for this product if it has fallen into liquid. There is a risk of deadly electrical shock. Unplug the system immediately.

WARNING

☞ Do not use this product in an area where it can fall or be pulled into water or other liquids.

☞ Pay attention to the **permissible maximum ambient and gas inlet temperatures** (see “Technical data”, pg. 24).

CAUTION

- Adopt suitable measures in case of differences from recommended conditions, e.g., using the equipment outdoors, installation in altitudes of more than 6500 ft (2000 m) above mean sea level, conductive pollution or external condensation on the pump.
- Do not operate this product near flames.

NOTICE

To the best of our knowledge the equipment is in compliance with the requirements of the applicable EC-directives and harmonized standards (see "Declaration of Conformity") with regard to design, type and model. Directive EN 61010-1 gives in detail the conditions under which the equipment can be operated safely (see also IP degree of protection, "Technical data", pg. 24).

Operating conditions**DANGER**

- ➔ These pumps are not approved for operation in potentially explosive atmospheres. **Do not operate the pumps in potentially explosive atmospheres.**
- ➔ Pumps **without the "Ex" mark on the rating plate** are **not approved for the pumping of potentially explosive atmospheres. Do not pump potentially explosive atmospheres** with those pumps.
- ➔ Pumps **bearing the "Ex" mark on their rating plates** are **approved for the pumping of potentially explosive atmospheres** according to their classification **II 3G IIC T3 X** according to ATEX, but they are **not approved for operation in potentially explosive atmospheres** (see section "Ex Important information: Equipment marking (ATEX)", pg. 22).
- ➔ The pumps are **not suitable** to pump any of the substances listed below.
Do not pump:
 - **unstable substances**
 - substances which react explosively under **impact** (mechanical stress) without air

- substances which react explosively when being exposed to **elevated temperatures** without air,
- substances subject to **auto-ignition**,
- substances which are **inflammable without air**
- **explosive substances**.

➔ The pumps are **not approved** for operation below ground. **Do not operate** the pump **below ground**.



☞ The pumps are **not suitable** for pumping dust. **Do not pump dust**.



- **Do not pump** substances which may form **deposits** inside the pump. The pumps are not suitable for pumping substances which may form deposits inside the pump. Deposits and condensate in the pump may lead to increased temperatures even to the point of exceeding the maximum permitted temperatures.
- Check the inlet and outlet of the pump, if there is a danger of forming **deposits** inside the pump, e.g., in the pump chambers (the pump chamber is the part between diaphragm and head cover. See section “Replacing diaphragms and valves”, pg. 38). Inspect the pump chambers regularly and clean if necessary.
- **Consider interactions and chemical reactions of the pumped media.** Ensure that the materials of the pump’s wetted parts are compatible with the pumped substances, see section “Technical data”, pg. 24. When changing the substances pumped, we recommend purging the pump with air or inert gas prior to changing the pumped media. Purging the pump will pump out residues and it will reduce the possibility of reactions of the pumped substances with each other and with the pump’s materials.

Safety during operation

! DANGER

- ➔ Adopt suitable measures to prevent the release of dangerous, toxic, explosive, corrosive, noxious or polluting fluids, vapors and gases. To prevent any emission of such substances from the pump outlet, install an appropriate collecting and disposal system and take protective action for pump and environment.
- ➔ You must take suitable precautions to prevent any formation of explosive mixtures in the pump chamber or at the outlet of the pump. In case, e.g., of a diaphragm failure, mechanically generated sparks, hot surfaces or static electricity may ignite these mixtures. Use inert gas for gas ballast or venting, if necessary.
- ➔ Drain appropriately or otherwise remove any potentially explosive mixtures at the outlet of the pump, or dilute them with inert gas to non-explosive concentrations.
- ➔ Never operate this pump if it has a damaged cord or plug.

! WARNING

- ☞ If the pump is not working properly, has been dropped or has fallen into water, contact your pump service provider.
- ☞ Prevent any part of the human body from coming into contact with vacuum.
- ☞ Never aspirate liquids or dust into the pump.
- ☞ Make sure that the exhaust tubing cannot become blocked.
- ☞ Comply with applicable regulations when disposing of chemicals. Take into consideration that chemicals may be contaminated. Take adequate precautions to protect people from the effects of dangerous substances (chemicals, thermal decomposition products of fluoroelastomers). Use appropriate protective clothing and safety goggles.

- ☞ Use only **original manufacturer's spare parts and accessories**. Otherwise the safety and performance of the equipment, as well as the electromagnetic compatibility of the equipment might be reduced.
The CE mark may be voided if not using original manufacturer's spare parts.

- ☞ Interruption of the pump (e.g., due to power failure), failure of connected components or of parts of the supply, or change in parameters must not be allowed to lead to dangerous conditions. In case of a diaphragm failure or in case of a leak in the manifold, pumped substances might be released into the environment or into the pump housing or motor.
Comply with all notes regarding proper use of the pumps, as well as operation and maintenance guidance.

- ☞ The residual **leak rate of the equipment** might render possible an exchange of gas, albeit extremely slight, between the environment and the vacuum system.
Adopt suitable measures to prevent contamination of the pumped substances or the environment.



- Ensure that no parts of your clothing, hair or fingers can be caught or drawn in at the inlet of the pump. Never insert fingers or drop any other object into the inlet or outlet.



- Pay attention to the safety symbol "hot surfaces" on the equipment. Hot parts may cause burns if touched. Adopt suitable measures to prevent any danger arising from hot surfaces or electric sparks. Ensure that hot surfaces of the pump do not cause burns. Provide a suitable contact guard if necessary.

- Pumping at high inlet pressure may lead to overpressure at the gas ballast valve. Pumped gases or condensate might be expelled if the valve is open. If an inert gas supply is connected to the gas ballast, ensure that its inlet pipeline is not contaminated.

NOTICE

Do not start the pump if the pressure difference between inlet and outlet exceeds 16 psi (1.1 bar) at maximum. Prevent the backpressure of gases and the backflow of condensates at the outlet.

Provide appropriate protective measures to allow for the possibility of failure and **malfunction**. The protective measures must also allow for the requirements of the respective application.

In case of overload, the motor is shut down by a **self-hold thermal cutout** in the winding.

Note: Only manual reset is possible. Switch off the pump and disconnect from the power source. Identify and eliminate the cause of failure. Wait approx. five minutes before restarting the pump.

CAUTION

- **Note:** In case of **supply voltage below 100V**, the lock of the cutout might be impaired and the pump may restart on its own after sufficient cooling down. Take appropriate precautions, if an automatic restart of the pump may lead to a dangerous situation (e.g., switch off the pump and disconnect from the power source).

Maintenance and repair

NOTICE

In order to comply with laws (occupational, health and safety regulations, safety at work law and regulations for environmental protection) vacuum pumps, components and measuring instruments can only be returned when certain procedures (see section "Notes on return to the factory", pg. 50) are followed.

Take advantage of our service seminars, which put special focus on the maintenance and repair of vacuum pumps. For details and for the online "Instructions for repair" manual see www.vacuubrand.com.

In case of normal wear, the lifetime of the diaphragms and valves is > 10000 operating hours. Bearings have a

typical durability of 40000 h. Motor capacitors have a typical durability in the range of 10000 to 40000 h depending strongly on operation conditions including ambient temperature, humidity or load.

! DANGER

➔ **Ensure that the pump cannot be operated accidentally. Never operate the pump if covers or other parts of the pump are disassembled.**



➔ **Switch off the pump. Disconnect the electrical power cord and wait two minutes** before starting maintenance to allow the capacitors to discharge.

➔ **Note:** The pump may be contaminated with process chemicals, which have been pumped during operation. Ensure that the pump is completely decontaminated before maintenance commences.

! WARNING

☞ Take adequate precautions to protect people from the effects of dangerous substances if contamination has occurred. Use appropriate protective clothing, safety goggles and protective gloves.

☞ **Wear parts have to be replaced regularly.**

☞ **Never operate a defective or damaged pump.**

☞ Check every motor capacitor regularly by measuring its capacity and estimating its time in operation. Replace old capacitors early enough to prevent a failure in operation. If an old motor capacitor fails, the capacitor may get hot. It may even melt or emit a flame, which could be **dangerous for persons and equipment in the vicinity**. The capacitors have to be replaced by an electrician.

☞ Vent the pump before starting maintenance. Isolate the pump and other components from the vacuum system. Allow sufficient cooling of the pump.

NOTICE

Ensure that **maintenance** is done only by suitably trained and supervised technicians. Ensure that the maintenance technician is familiar with the safety procedures, which relate to the products processed by the pumping system.

Only dismantle the pump as far as necessary.



 Important information: Equipment marking (ATEX)**VACUUBRAND equipment bearing mark (see rating plate)**

 II 3G IIC T3 X
Internal Atm. only
Tech. File Ref.: VAC-EX01

and

VACUUBRAND equipment bearing mark (see rating plate)

 X see manual

For equipment labelled with „ X see manual“ the following classification according to Directive 94/9/EC (ATEX) is valid:  II 3G IIC T3 X, Internal Atm. only, Tech. File Ref.: VAC-EX01.

The classification II 3G IIC T3 X according to ATEX is only valid for the inner part (wetted part, pumped gas or vapor) of the equipment. The equipment is not suitable for use in external, potentially explosive atmospheres (environment).

The overall category of the equipment depends on the connected components. If the connected components do not comply with the classification of the VACUUBRAND equipment, the specified category of the VACUUBRAND equipment is no longer valid.

Vacuum pumps and vacuum gauges in category 3 are intended for connection to equipment in which during normal operation explosive atmospheres caused by gases, vapors or mists normally don't occur; or, if they do occur, are likely to do so only infrequently and for a short period only. Equipment in this category ensures the requisite level of protection during normal operation.

The use of gas ballast or the operation of venting valves is only permitted if thereby explosive atmospheres normally don't occur in the interior of the equipment or, if they do occur, are likely to do so only infrequently and for a short period.

The pumps are marked with "X" (according to EN 13463-1), i.e., restrictions of the operation conditions:

- The equipment is designated for a low degree of mechanical stress and has to be installed in a way so that it cannot be damaged from outside.
Pumping units have to be installed so that they are protected against shocks from the outside and against glass splinters in the event of breakage (implosion).
- The equipment is designated for an ambient and gas inlet temperature during operation of +10 to +40°C. Never exceed these ambient and gas inlet temperatures. If pumping / measuring gases which are not potentially explosive, extended gas inlet temperatures are permissible. See instructions for use, section "Gas inlet temperatures" or "Technical data".

After any intervention at the equipment (e.g., repair / maintenance) the ultimate vacuum of the pump has to be checked. Only if the pump achieves its specified ultimate vacuum is the pump's leak rate low enough to ensure that no explosive atmospheres will occur in the interior of the equipment.

After any intervention at the vacuum sensor, the leak rate of the equipment has to be checked.



Attention: This manual is not available in all languages of the EU. The user must not operate the device if he does not understand this manual. In such a case, a technically correct translation of the complete manual has to be available. The manual must be completely read and understood before operation of the device and all required measures must be applied.

Technical data

General technical data valid for all pumps		
Maximum permissible inlet pressure (absolute)	psi (bar)	16 (1.1)
Maximum permissible outlet pressure (absolute)	psi (bar)	16 (1.1)
Maximum pressure difference between inlet and outlet	psi (bar)	16 (1.1)
Permissible ambient temperature storage / operation	°F (°C)	14 to 140 / 50 to 104 (-10 to +60 / +10 to +40)
Permissible relative atmospheric moisture during operation (no condensation)	%	30 to 85
No-load speed 50/60 Hz	rpm	1500 / 1800
Device fuse		slow blow fuse 2.5 A
Motor protection		thermal cutout, manual reset*
Degree of protection IEC 529		IP 40
A-weighted emission sound pressure level** (uncertainty K_{pA} : 3 dB(A))	dB(A)	45

* In case of supply voltage below 100V, the lock of the cutout might be impaired.

** Measurement according to EN ISO 2151:2004 and EN ISO 3744:1995 at 230V/50Hz and at ultimate vacuum with exhaust tube (ME 1C / MZ 1C) or with silencer (ME 1) at outlet.

Gas inlet temperatures

Operating condition	Inlet pressure	Permitted range of gas temperatures at inlet
Continuous operation	> 75 Torr (100 mbar) (high gas load)	➔ 50 °F to 104 °F (+10°C to +40°C)
Continuous operation	< 75 Torr (100 mbar) (low gas load)	➔ 32 °F to 140 °F* (0°C to +60°C*)
Short-time (< 5 minutes)	< 75 Torr (100 mbar) (low gas load)	➔ 14 °F to 176 °F* (-10°C to +80°C*)

* if pumping potentially explosive atmospheres: 50 °F to 104 °F (+10°C to +40°C)

Type		ME 1	ME 1C
Maximum pumping speed 50/60 Hz (ISO 21360)	cfm (m ³ /h)	0.4/ 0.5 (0.7 / 0.85)	
Ultimate vacuum (absolute)	Torr (mbar)	75 (100)	
Rated motor power	hp (kW)	0.054 (0.04)	
Maximum permissible range of supply voltage (±10%) Attention: Observe specifications of rating plate! Dual voltage motor		100-120 V~ 50/60 Hz 230 V~ 50/60 Hz 100-120 V~ 50/60 Hz / 200-230 V~ 50/60 Hz	
Maximum rated current at: 100-120 V~ 50/60 Hz 200-230 V~ 50/60 Hz 230 V~ 50/60 Hz	A A A	1.9 / 1.4 0.8 / 0.6 0.8 / 0.6	
Inlet		hose nozzle for tubing I.D. 1/4" / 3/8" (hose nozzle DN 6/10 mm) / internal thread G 1/8"	hose nozzle for tubing I.D. 3/8" (hose nozzle DN 10 mm)
Outlet		silencer / internal thread G 1/8"	hose nozzle for tubing I.D. 3/8" (hose nozzle DN 10 mm)
Dimensions L x W x H approx.	in (mm)	9.7 x 4.8 x 5.7 (247 x 121 x 145)	
Weight approx. 100-120 V version 230 V version 100-120 V / 200-230 V version	lbs. (kg) lbs. (kg) lbs. (kg)	11.9 (5.4) 11.0 (5.0) 11.9 (5.4)	

We reserve the right for technical modification without prior notice!

Type		MZ 1C
Maximum pumping speed 50/60 Hz (ISO 21360)	cfm (m ³ /h)	0.44 / 0.53 (0.75 / 0.9)
Ultimate vacuum (absolute) without gas ballast	Torr (mbar)	9 (12)
Ultimate vacuum (absolute) with gas ballast	Torr (mbar)	15 (20)
Maximum permissible pressure (absolute) at gas ballast valve	psi (bar)	17.5 (1.2)
Rated motor power	hp (kW)	0.08 (0.06)
Maximum permissible range of supply voltage (±10%) Attention: Observe specifications of rating plate! Dual voltage motor		100-120 V~ 50/60 Hz 230 V~ 50/60 Hz 100-120 V~ 50/60 Hz / 200-230 V~ 50/60 Hz
Maximum rated current at: 100-120 V~ 50/60 Hz 200-230 V~ 50/60 Hz 230 V~ 50/60 Hz	A A A	2.0 / 1.4 1.0 / 0.7 0.8 / 0.6
Inlet		hose nozzle for tubing I.D. 3/8" (hose nozzle DN 10 mm)
Outlet		hose nozzle for tubing I.D. 3/8" (hose nozzle DN 10 mm)
Dimensions L x W x H approx.	in (mm)	12.3 x 4.8 x 6.7 (312 x 121 x 170)
Weight approx.	lbs. (kg)	14.8 (6.7)

We reserve the right for technical modification without prior notice!

Wetted parts

Components	Wetted materials		
	ME 1	ME 1C	MZ 1C
Housing cover	Aluminum alloy (AlMgSi)	-	-
Housing cover insert	-	PTFE carbon reinforced	PTFE carbon reinforced
Head cover	Aluminum alloy (AlMgSi)	ETFE	ETFE
Diaphragm clamping disc	Aluminum alloy (AlMgSi)	ETFE carbon fiber reinforced	ETFE carbon fiber reinforced
Diaphragm	PTFE	PTFE	PTFE
Valves	PTFE	PTFE	PTFE / FFKM
Inlet	Aluminum alloy (AlMgSi)	ETFE	ETFE
Outlet	PA / PE / aluminum alloy	ETFE	ETFE
Gas ballast tube	-	-	PTFE

Abbreviations

ETFE: Ethylene/Tetrafluoroethylene

FFKM: Perfluoro elastomer

PTFE: Polytetrafluoroethylene

PA: Polyamide

PE: Polyethylene

Pump parts

Position	Component
1	Power connection
2	ON/OFF switch
3	Pump rating plate
4	Inlet
5	Outlet
6	Fan
7	Gas ballast

We reserve the right for technical modification without prior notice!

ME 1

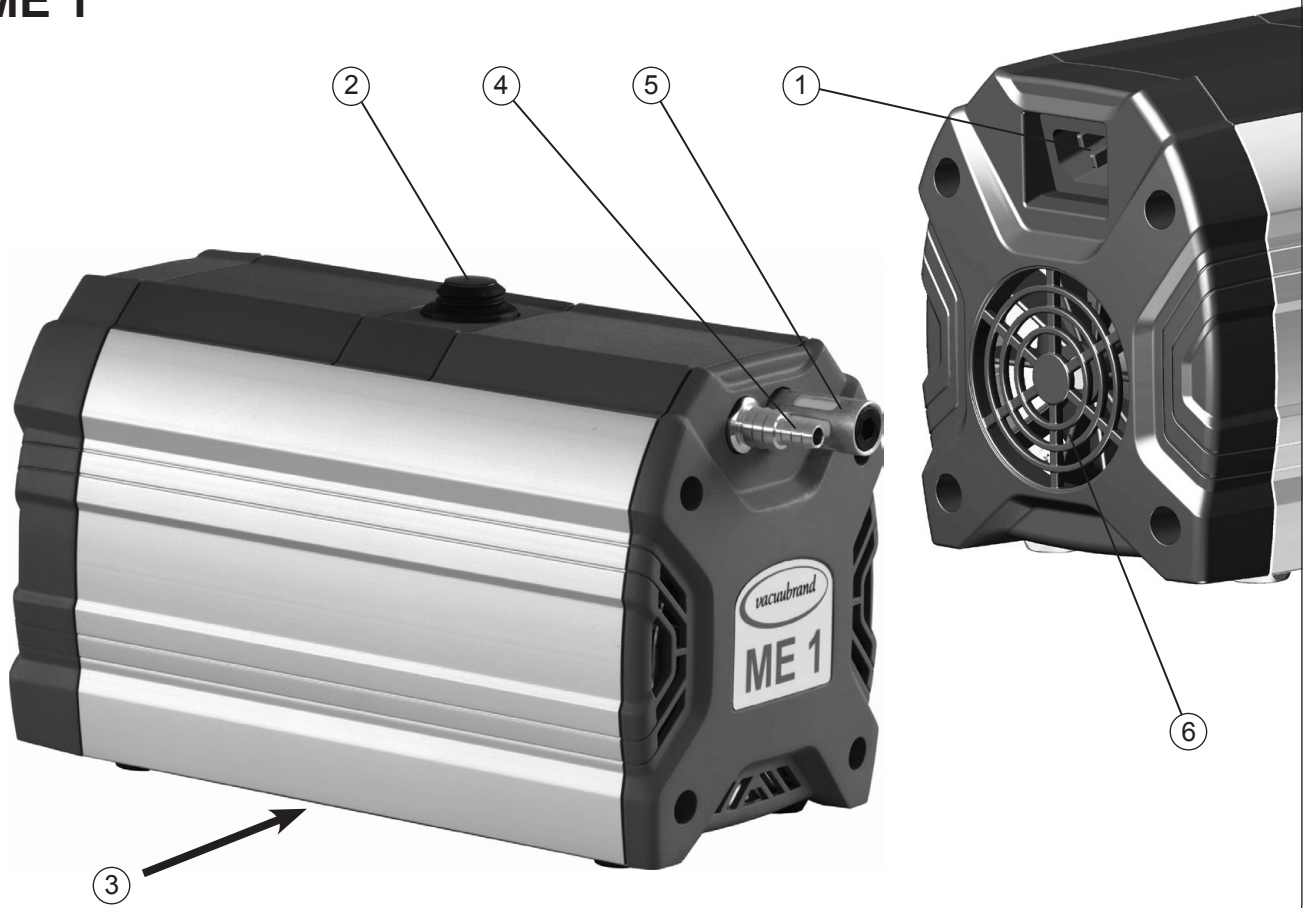

ME 1C



MZ 1C

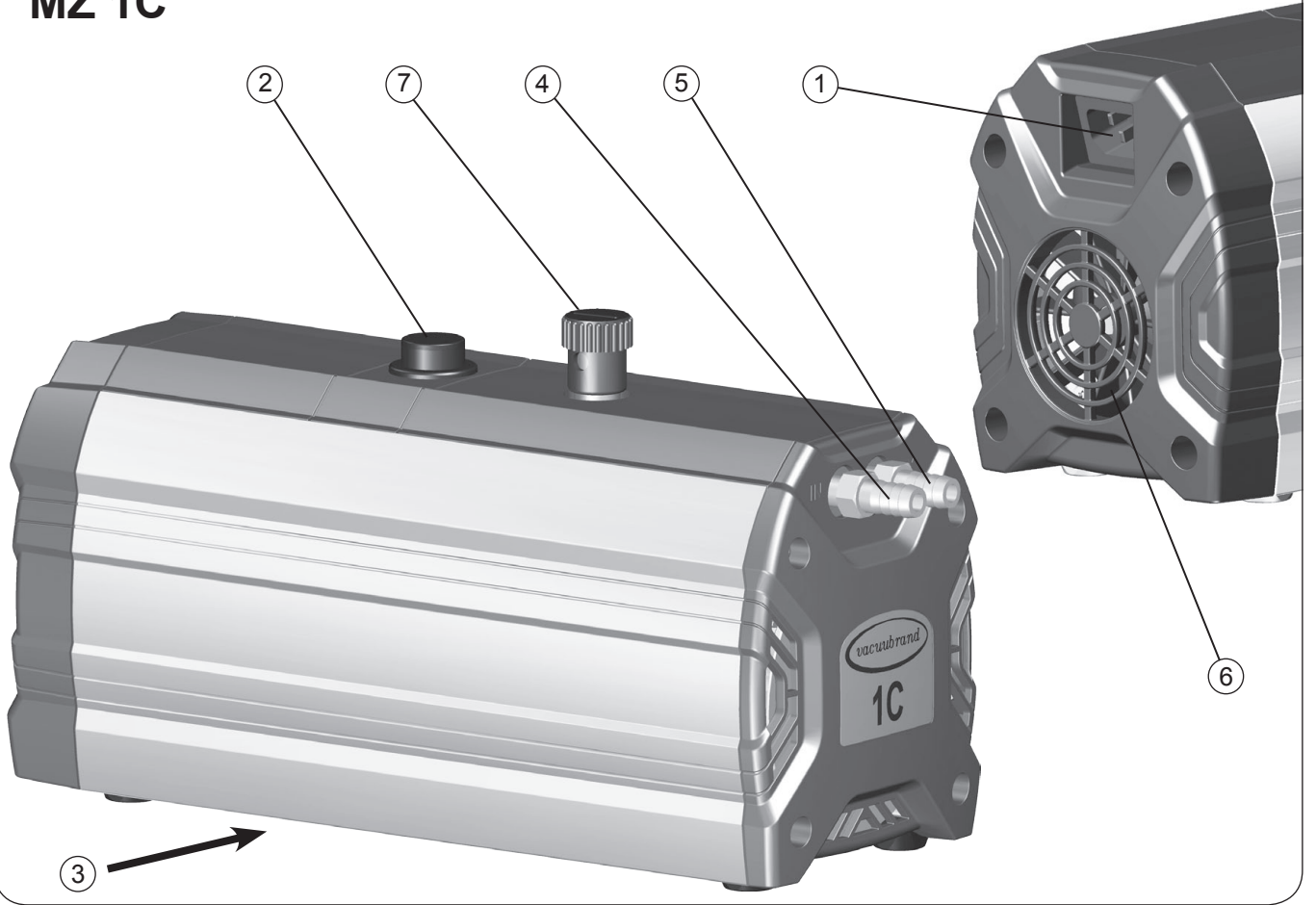

ON/OFF switch



pump switched off



pump switched on

Use and operation

Installing a pump in a vacuum system

DANGER

- ➔ If dangerous or polluting fluids could be released at the outlet, install an appropriate system to catch and dispose of those fluids.

WARNING

- ➔ Connect a gas-tight exhaust line at the pump outlet if necessary. Always vent exhaust gases appropriately (e.g., into a fume hood).
- ➔ Never block the gas outlet. The exhaust line must always be free of obstructions (no back pressure) to ensure an unimpeded discharge of gas. The cross-section of the outlet tubing must be at least the size of the pump's exhaust connection.
- ➔ Particles and dust must not be aspirated. If necessary, you must install appropriate filters. You must ensure their suitability concerning gas flow, chemical resistance and resistance to clogging prior to use.
- ➔ Make sure ventilation is adequate, especially if the pump is installed in an enclosure, or if the ambient temperature is elevated. Provide external ventilation, if necessary.

CAUTION

- Reduce the transmission of vibration. Prevent mechanical load due to rigid tubing. Insert elastic hoses or flexible elements as couplings between the pump and rigid pipes. **Note:** Flexible elements will compress or flatten when evacuated if not designed for use under vacuum.
- Hose connections at the pump inlet must always be gas tight.
- A power failure may cause accidental ventilation of the pump, especially if the gas ballast valve is open. If this constitutes a potential source of danger, take appropriate safety measures.

- Check the power source and the pump's rating plate to be sure that the power source and the equipment match in voltage, phase, and frequency.
- **Pump with dual-voltage motor:** Check that the voltage selection switch is positioned correctly. Check every time before starting the pump.

Note: If the pump is switched on with wrong voltage selection, the motor may be damaged!

Change the selection at the voltage selection switch only, if the pump is unplugged from the power source.

Voltage selection switch:

1. **Disconnect the electrical power cord.**
2. Use a screw driver to adjust the **voltage selection switch** to the supply voltage:

"115" corresponds to 90-132 V and
"230" corresponds to 180-253 V.



voltage selection switch

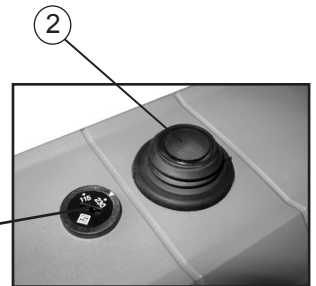

NOTICE

Keep a distance of minimum 8 in (20 cm) between fan and adjacent equipment or casework.

Use connecting hoses with large diameter and keep them as short as possible to avoid flow losses. Locate the pump as closely as possible to the application.

Always install outlet tubing descending from the pump to avoid backflow of condensate towards the pump.

To reduce pump noise emanating from the pump exhaust port, connect an exhaust hose or use a silencer (see "Accessories", pg. 35)

When assembling, ensure **vacuum-tightness**. After assembly, check the whole system for leaks.

Secure hose connections at the pump appropriately, e.g., with hose clamps, to protect against accidental detachment.

During operation

DANGER

- ➔ Vent and dispose of **potentially dangerous gases or vapors** at the outlet of the pump appropriately.

WARNING

- ☞ Due to the high compression ratio, the pump might generate overpressure at the outlet. Check pressure compatibility with system components (e.g., exhaust tubing or exhaust valve) at the outlet. Ensure that the pump outlet is neither blocked nor restricted.

- ☞ **Maximum ambient temperature:** 104 °F (40 °C)

Check the maximum temperatures, if installing the pump in a cabinet or a housing. Make sure ventilation is adequate, especially if the ambient temperature is elevated.

- ☞ Operation with silencer at the outlet: Operating the pump at a high inlet pressure or pumping dusty gases for a long time may cause clogging of the silencer. Check the silencer regularly and replace if necessary.

CAUTION

- If the pump is installed at an altitude of more than 6500 ft (2000 m) above mean sea level, check compatibility with applicable safety requirements, and adopt suitable measures. There is a risk of the motor overheating due to insufficient cooling.
- Check compatibility with the **maximally permitted pressure** at outlet and the **maximum pressure difference** between inlet and outlet ports.

NOTICE

If pumping condensable vapors (water vapor, solvents, etc.), let the pump run with **gas ballast** to help purge any condensation in the pump.

Do not start the pump if the **pressure difference between inlet and outlet ports exceeds max. 16.0 psi (1.1 bar)**. Attempts to start the pump at higher pressure difference may cause stalling and damage of the motor. Prevent internal condensation, transfer of liquids or dust.

The diaphragms and valves will be damaged, if liquids are pumped in significant amounts.

Check the pump regularly for external soiling and deposits. Clean the pump if necessary to avoid an increase of the pump's operating temperature.

In case of overload, the motor is shut down by a **self-hold thermal circuit breaker** in the winding.

Note: Only a manual reset is possible. Switch off the pump and disconnect the electrical power cord. Identify and eliminate the cause of failure. Wait approximately five minutes before restarting the pump.

CAUTION

- **Note:** In case of **supply voltage below 100V**, the lock of the breaker may not latch and the pump might restart on its own after sufficient cooling. Take appropriate precautions, if an automatic restart of the pump may lead to a dangerous situation.

NOTICE

A warm up period (approximately 15 min.) is required to ensure that the rated ultimate vacuum and pumping speed are attained. Avoid overheating (e.g., due to hot process gases).

Important notes regarding the use of gas ballast

Gas ballast is a continuous purge to keep the pump's interior as clean as possible and to reduce the possibility of condensation inside the pump.

DANGER

- ➔ Air and pumped media might react inside the pump or at the outlet of the pump and form hazardous or explosive mixtures, when you use air rather than inert gas for the gas ballast. This constitutes a risk of significant damage to equipment and/or facilities, a risk of personal injury or even loss of life.

WARNING

- ☞ Make sure that air/gas intake through the gas ballast valve can never lead to hazardous, explosive or otherwise dangerous mixtures. If in doubt, use inert gas.

NOTICE

To reduce condensation in the pump, do not pump vapor before the pump has reached its operating temperature. Open the gas ballast valve when pumping condensable vapors. Turn gas ballast cap to open valve.

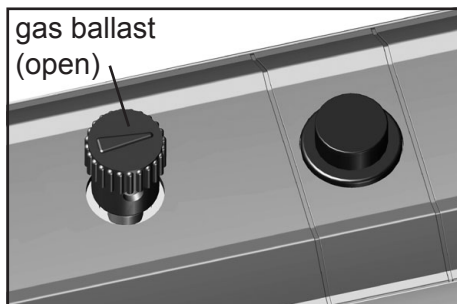

For **condensable vapors** (water vapor, solvents, etc.):

- The gas ballast valve is open if the arrow on the gas ballast cap is pointing towards the ON/OFF switch.
- With gas ballast valve open, the ultimate vacuum will be reduced.
- Use inert gas for gas ballast to avoid the formation of explosive mixtures.
- Close the gas ballast valve by turning the cap 180°.

In case of low boiling solvents (when the formation of condensate is unlikely), the use of gas ballast might be unnecessary.

Shutdown & storage

The pump can be switched off under vacuum.

NOTICE

Short-term:

Has the pump been exposed to condensate?

- Allow the pump to continue to run at atmospheric pressure for a few minutes.

Has the pump been exposed to media which may damage the pump materials or form **deposits**?

- Check and clean pump heads if necessary.

Long-term:

Take measures as described above regarding short-term shutdown.

Separate the pump from the application.

Close inlet and outlet ports (e.g., with transport caps).

Close the gas ballast valve.

Store the pump under dry conditions.

Accessories



Digital vacuum gauge DVR 2 **682902**

Vacuum hose (caoutchouc) I.D. 3/8" (10 mm ID) **686002**

Silencer for hose nozzle 3/8" (DN 10 mm) **636588**

Attention: Dust-laden gases, deposits and condensed solvent vapor can restrict air flow out the silencer. The resultant back pressure can lead to damage of pump bearings, diaphragms, and valves. Under those conditions, a silencer must not be used.

Upgrade possibilities:

CVC 3000 Controller..... **683160**

In-line valve VV-B 6C **674291**

Kit "Vacuum adjustment device" **696842**

with manometer for **ME 1**

Kit "Vacuum adjustment device" **696843**

with manometer for **ME 1C / MZ 1C**

For additional accessories such as vacuum valves, small-flange components, vacuum gauges or vacuum controllers refer to www.vacuubrand.com

Troubleshooting

Fault	Possible cause	Remedy
<input type="checkbox"/> Pump does not start or stops immediately.	<ul style="list-style-type: none"> ➔ Electrical power cord not plugged in, electrical supply failure? ➔ Device fuse blown? ➔ Overpressure in outlet line? ➔ Motor overloaded? 	<ul style="list-style-type: none"> ✓ Plug in power cord. Check fuse. Check supply voltage. ✓ Identify cause of failure. Replace device fuses. ✓ Remove blockage in line, open valve. ✓ Allow motor to cool down, identify and eliminate cause of failure. Manual reset is necessary. Switch off pump or unplug.
<input type="checkbox"/> Pump does not achieve its ultimate vacuum or usual pumping speed.	<ul style="list-style-type: none"> ➔ Leak in the tubing or vacuum system? ➔ Long, narrow vacuum line? ➔ Pump has been exposed to condensate? ➔ Deposits have been formed inside the pump? ➔ Diaphragms or valves damaged? ➔ Outgassing substances or vapor generated in the process? 	<ul style="list-style-type: none"> ✓ Check pump directly - connect vacuum gauge directly at pump inlet - then check connection, tubing and vacuum system if necessary. ✓ Use lines with larger diameter, length as short as possible. ✓ Allow pump to run for some minutes with atmospheric pressure at the inlet to purge. ✓ Clean and inspect the pump heads. ✓ Replace diaphragms and/or valves. ✓ Check process parameters.

Fault	Possible cause	Remedy
<input type="checkbox"/> Pump too noisy.	<ul style="list-style-type: none"> ➔ Atmospheric or high pressure at the pump inlet? ➔ Diaphragm crack or diaphragm clamping disc loose? ➔ Other than above mentioned causes? 	<ul style="list-style-type: none"> ✓ Connect hose or silencer to pump outlet. Be careful not to cause outlet over-pressure, especially with condensable vapors. ✓ Perform maintenance. ✓ Contact local distributor.
<input type="checkbox"/> Pump seized.		<ul style="list-style-type: none"> ✓ Contact local distributor.

- ➔ A service manual with exploded view drawings, spare parts list and directions for repair is available on request.
- 👉 The service manual is intended for trained service people only.

Replacing diaphragms and valves

☞ Please read section "Replacing diaphragms and valves" completely before starting maintenance.

The pictures may show other versions of pumps. This does not change the method of replacing diaphragms and valves.

! DANGER

➔ Never operate the pump if covers or other parts of the pump are disassembled.



➔ Before starting maintenance, **disconnect the electrical power cord. Wait two minutes** after isolating the equipment from AC power to allow the capacitors to discharge.

➔ Ensure that the pump cannot be operated accidentally.

➔ **Note:** The pump might be contaminated with the process chemicals that have been pumped during operation. Ensure that the pump is decontaminated before maintenance.

➔ Avoid the release of pollutants.

! WARNING

☞ Never operate a defective or damaged pump.

☞ Take adequate precautions to protect people from the effects of dangerous substances that may have contaminated the pump and may be released upon disassembly. Ensure that the maintenance technician is familiar with the safety procedures which relate to the products processed by the pumping system.

Use appropriate protective clothing, safety goggles and protective gloves.

☞ Check every motor capacitor regularly by measuring its capacity and estimating its service life. Replace old capacitors early enough to prevent a failure. The capacitors must be replaced by a trained electrician.

☞ Allow sufficient cooling of the pump before starting maintenance.

- ☞ **Vent the pump and isolate it from the vacuum system before you start maintenance.**

NOTICE

Ensure that maintenance is done only by suitably trained and supervised technicians.

The valves and diaphragms as well as the motor capacitors are wear parts. If the rated ultimate vacuum is no longer achieved or in case of increased noise level, the pump interior, the diaphragms and the valves must be cleaned and the diaphragms and valves must be checked for cracks or other damage.

All bearings are encapsulated and are filled with long-life lubricant. Under normal operating conditions, the drive system is maintenance free.

In demanding circumstances, it may be efficient to check and clean the pump heads on a regular basis. In normal use, the lifetime of the diaphragms and valves is more than 10,000 operating hours.

- Prevent internal condensation, transfer of liquids or dust. The diaphragms and valves will be damaged if liquid is pumped in significant amount.
- Carry out maintenance frequently if the pump is exposed to corrosive media or in case of deposits.
- Regular maintenance will improve the lifetime of the pump and also protect both users and the environment.

Service kit for ME 1 / ME 1C	696874
(diaphragm, valves, diaphragm key)	
Service kit for MZ 1C	696876
(diaphragms, valves, diaphragm key)	

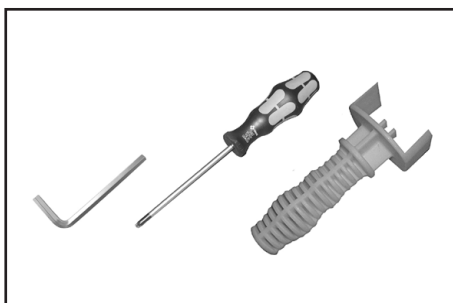

Tools required (metric):

- Diaphragm key width 46 mm (included in service kit)
- Torx driver T20
- slotted screwdriver (only for MZ 1C)
- 4 mm wide Allen key (only for MZ 1C)

Cleaning and inspecting the pump heads

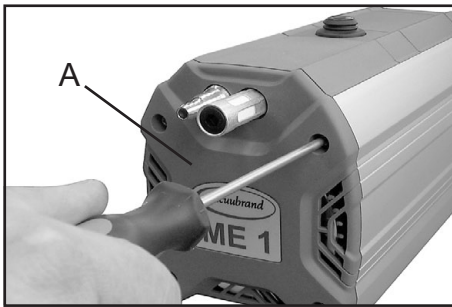

- Remove the 4 screws affixing the front cover (A) with a Torx driver T20. Pay attention to the washers under the screws.
- Pull off front cover carefully. Do not tilt.

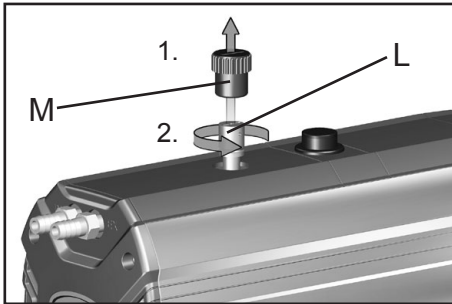

Only MZ 1C:

- Pull the gas ballast cap (M) off the gas ballast tube (L).
- Unscrew and remove the gas ballast tube. Use a slotted screwdriver if needed.

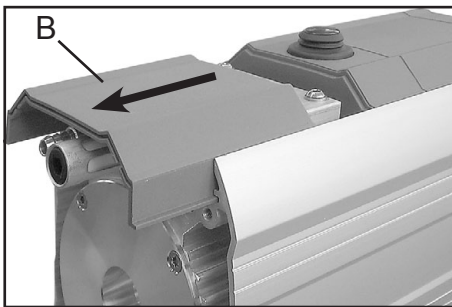

- Pull the upper cover (B) out of the housing.

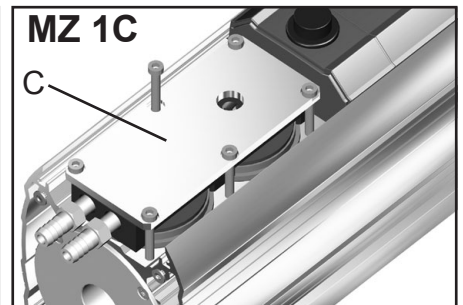
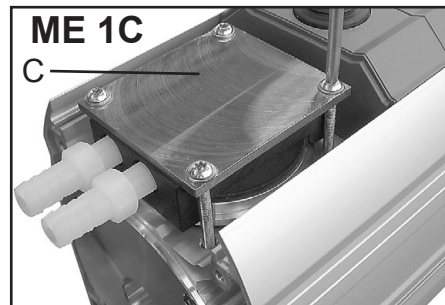
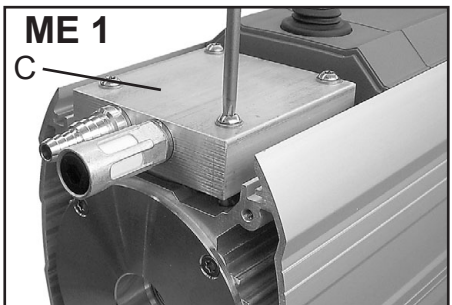

- Disassemble housing cover (C) to check the diaphragm and valves.

ME 1 / ME 1C:

- Unscrew four screws with a Torx driver T20. Remove the housing cover (C) (ME 1C: housing cover (C) with housing cover insert (C1)). Pay attention to the washers.

MZ 1C:

- Unscrew six Allen screws with a 4mm wide Allen key. Remove the housing cover (C) and the housing cover insert (C1).

- ⚠ Never use a pointed or sharp-edged tool to remove parts (e.g., screwdriver). We recommend using a rubber mallet or compressed air (to be blown carefully into port).

View of the disassembled pump head parts ME 1

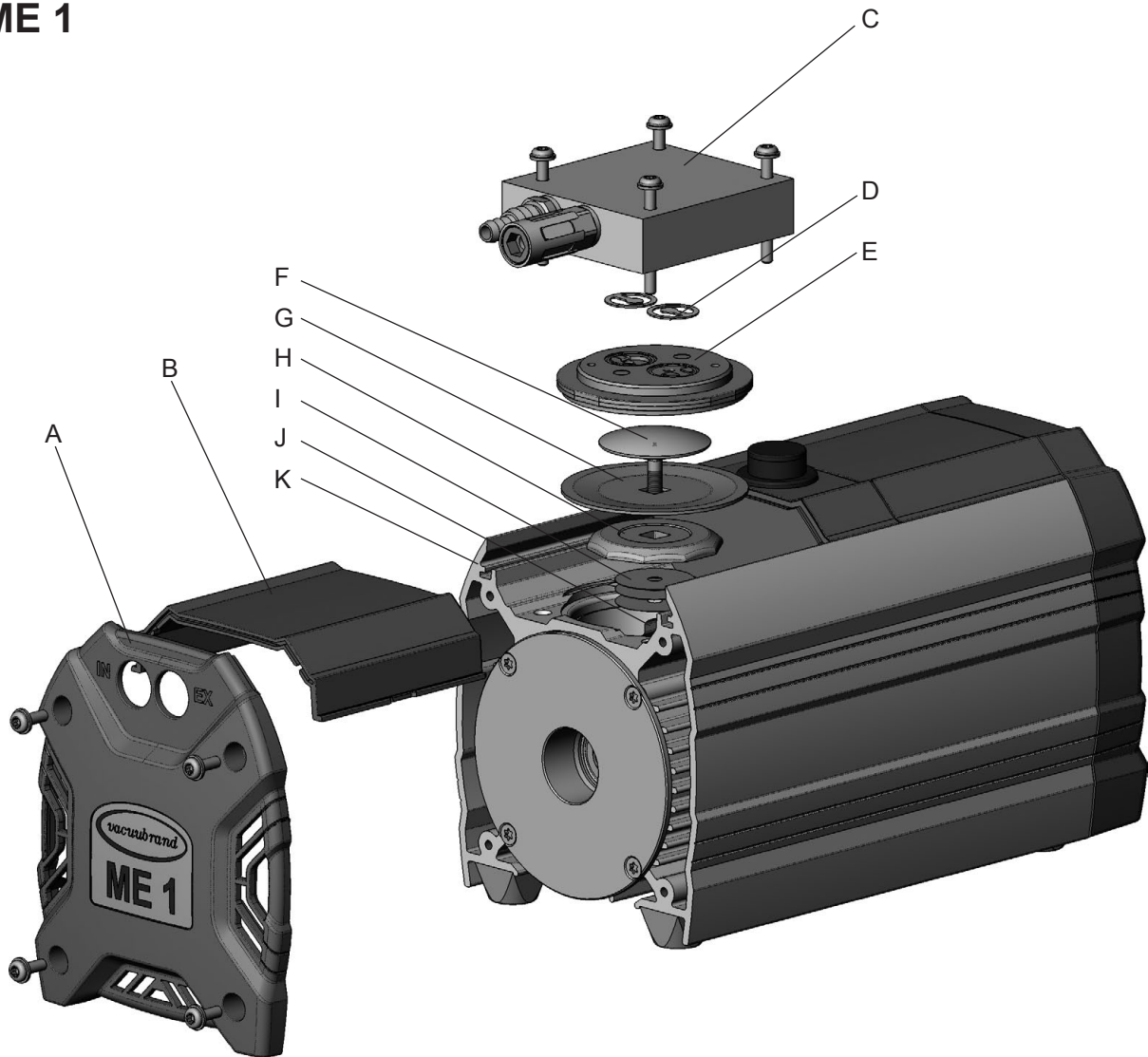

A: Front cover

B: Cover

C: Housing cover

D: Valve

E: Head cover

F: Diaphragm clamping disc
with square head screw

G: Diaphragm

H: Diaphragm support disc

I : Washers

J: Rod

K: Housing

This labeling is used throughout this chapter.

View of the disassembled pump head parts ME 1C

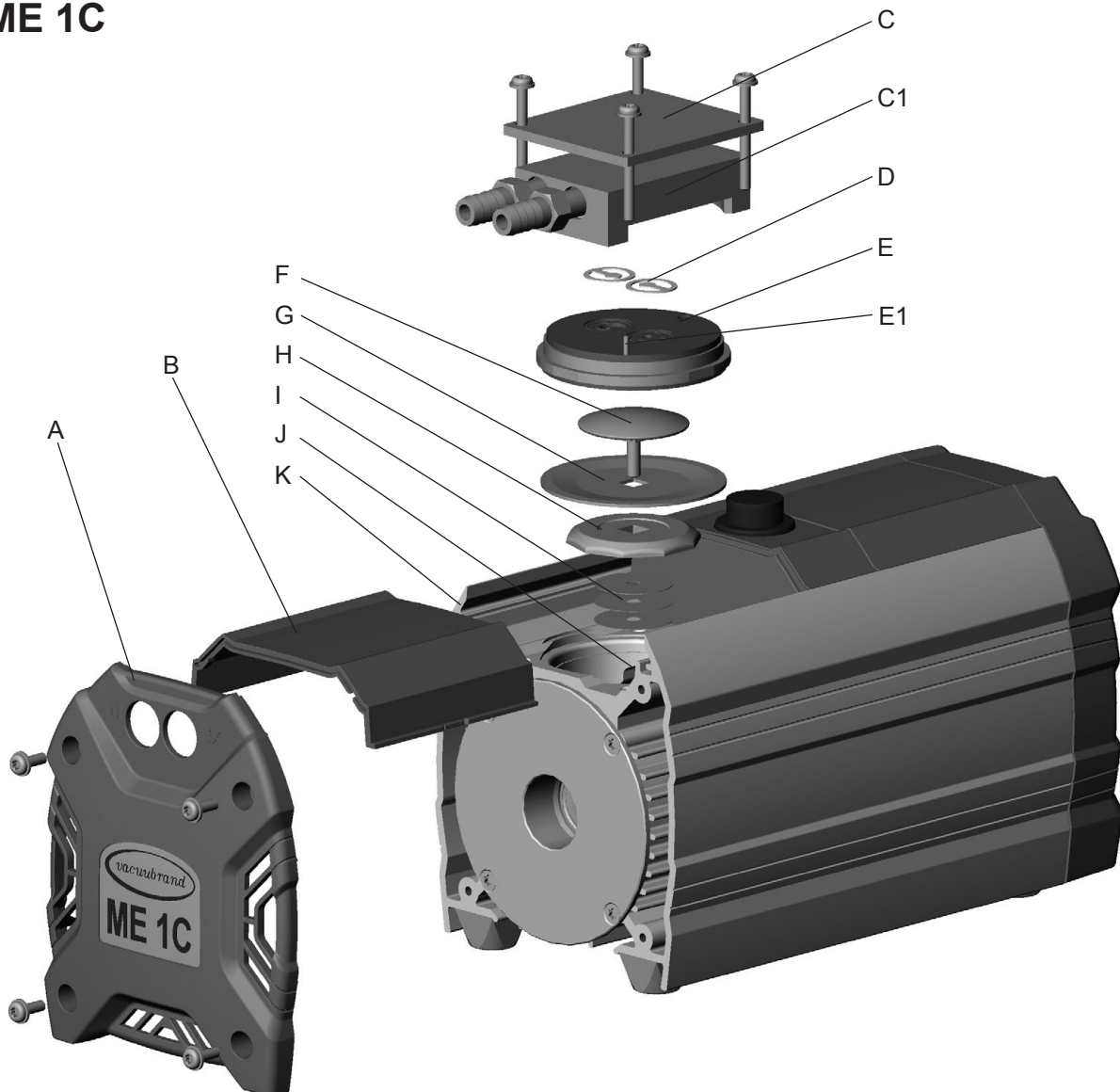

- | | | | |
|-----|----------------------|----|---|
| A: | Front cover | F: | Diaphragm clamping disc
with square head screw |
| B: | Cover | G: | Diaphragm |
| C: | Housing cover | H: | Diaphragm support disc |
| C1: | Housing cover insert | I: | Washers |
| D: | Valve | J: | Rod |
| E: | Head cover | K: | Housing |
| E1: | Guidance pin | | |

This labeling is used throughout this chapter.

View of the disassembled pump head parts MZ 1C

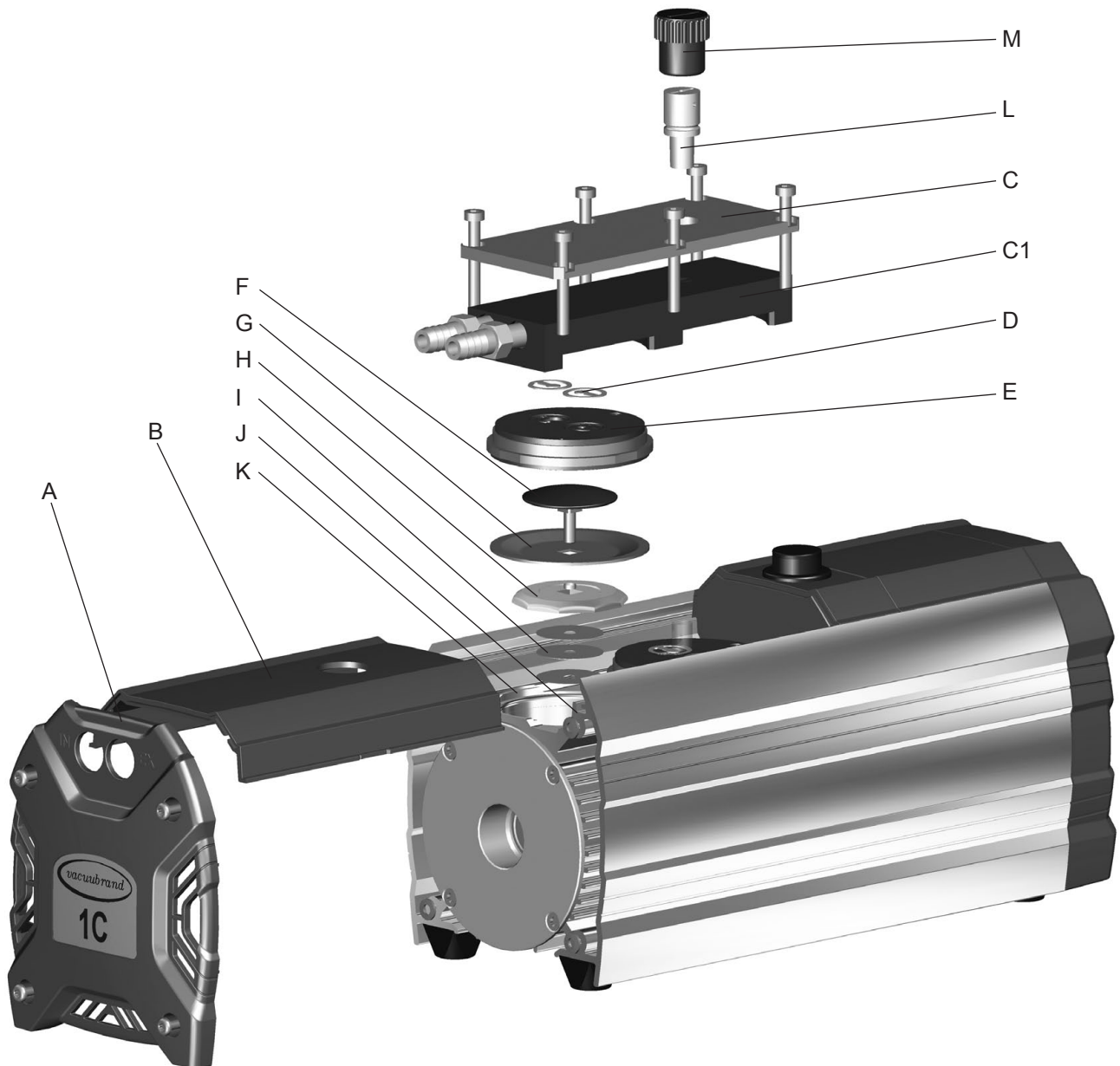

- | | | | |
|-----|---|----|------------------------|
| A: | Front cover | G: | Diaphragm |
| B: | Cover | H: | Diaphragm support disc |
| C: | Housing cover | I: | Washers |
| C1: | Housing cover insert | J: | Rod |
| D: | Valve | K: | Housing |
| E: | Head cover | L: | Gas ballast tube |
| F: | Diaphragm clamping disc
with square head screw | M: | Gas ballast cap |

This labeling is used throughout this chapter.

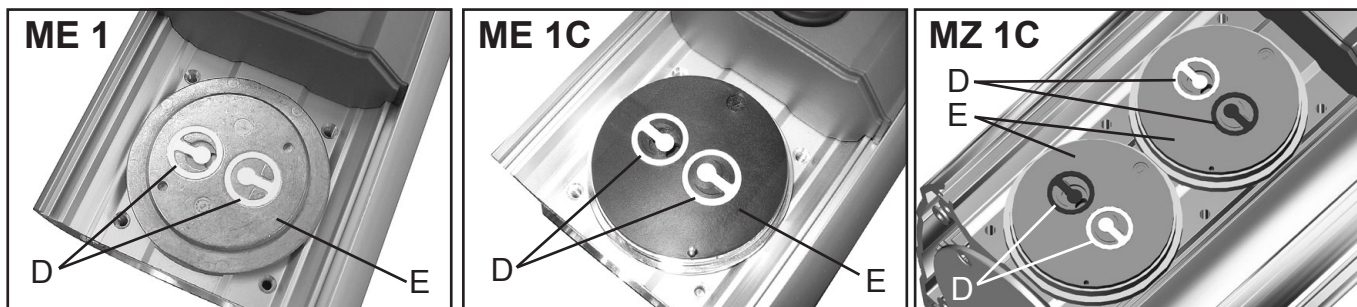

- Note position and alignment of valves (D). Remove the valves.
- ☞ Replace valves if necessary.
- ☞ Use petroleum ether or other industrial solvent to remove deposits. Do not inhale vapors.
- Remove the head cover (E).
- ☞ Check diaphragm (G) for damage and replace if necessary.

Replacing the diaphragm

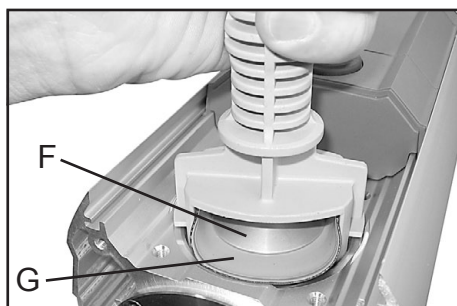

- Lift diaphragm carefully sidewise.
- ☞ Never use a pointed or sharp-edged tool to lift the diaphragm.
- Use the diaphragm key to grip the diaphragm support disc (H) below the diaphragm. Press down the diaphragm clamping disc (F) to bring the diaphragm into its lower turning point position.
- Press the diaphragm key against the diaphragm clamping disc and unscrew diaphragm support disc (H) with diaphragm (G) and diaphragm clamping disc (F).
- Check for washers (I) between the diaphragm support disc (H) and the connecting rod (J). Make sure that the original number is reassembled.
- ☞ Too few washers: The pump will not attain vacuum specification. Too many washers: Diaphragm clamping disc will hit head cover, causing noisy operation and possibly causing the pump to seize up.
- ☞ If the old diaphragm is difficult to separate from the diaphragm support disc, immerse assembly in naphtha or petroleum ether. Do not inhale vapors!

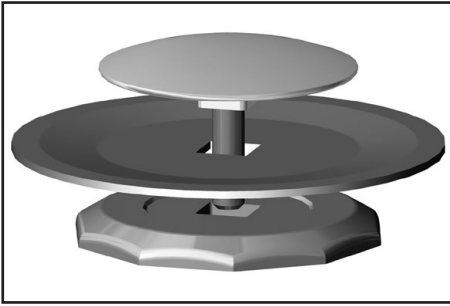

- ➔ Position new diaphragm (G) between diaphragm clamping disc with square head screw (F) and diaphragm support disc (H).
- ☞ **Note:** Position diaphragm with pale side towards diaphragm clamping disc (facing pump chamber).

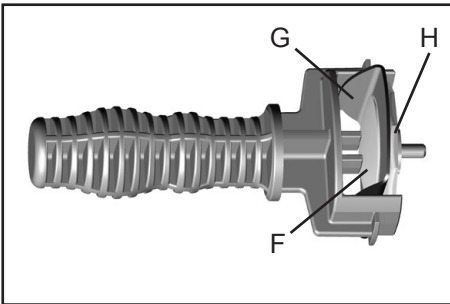

- ☞ Make sure that the square head screw of the diaphragm clamping disc is correctly seated in the guide hole of the diaphragm support disc.
- ➔ Lift the diaphragm at the side. Place the diaphragm carefully together with diaphragm clamping disc and diaphragm support disc in the diaphragm key.
- ☞ Avoid damage of the diaphragm: Do not excessively bend or crease the diaphragm.

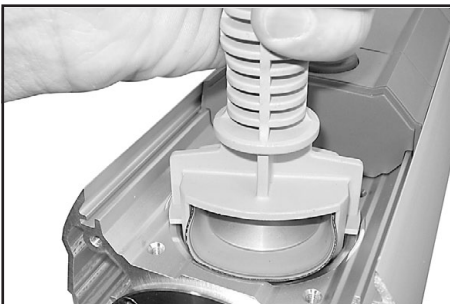

- ☞ Assemble the original number of washers (I) between diaphragm support disc (H) and connecting rod (J).
- ➔ Screw diaphragm clamping disc (F), diaphragm (G), diaphragm support disc (H), and washers (I) to connecting rod (J).

- ➔ Optimum torque for the diaphragm support disc: 3 ft·lb_f (4 Nm).

Assembling the pump head

- ➔ Bring the diaphragm (G) into a position, in which it is in contact with the housing (K) and centered with respect to the bore so that it will become clamped uniformly between housing (K) and head cover (E).

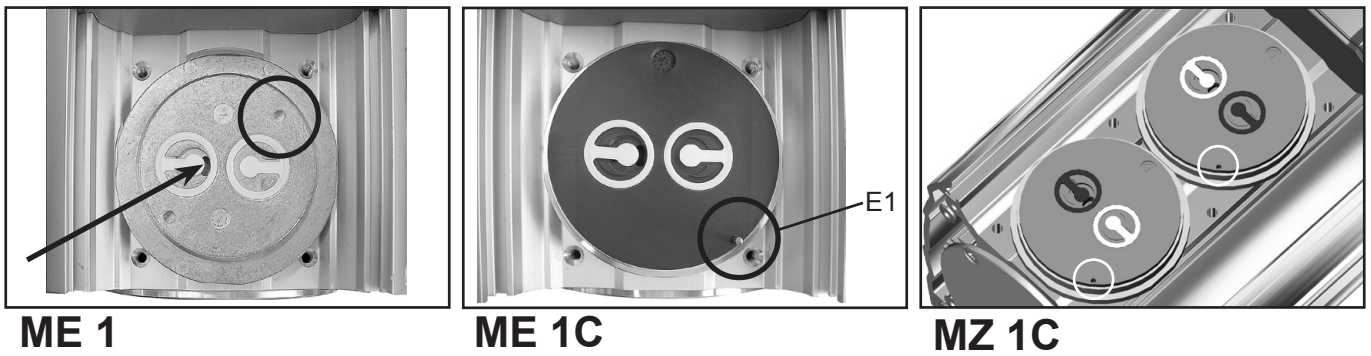

- ➔ Put on head cover (E).
- ☞ Pay attention to the correct orientation of the head cover:
 - ME 1:** Pay attention to the correct position of the kidney-shaped orifice in the valve seat (see arrow in figure above) and to the correct position of the indentation in the head cover (circle in figure above) for the guidance pin of the housing cover!
 - ME 1C:** Pay attention to the correct position of the guidance pin (E1) in the head cover (circle in figure above)!
 - MZ 1C:** Pay attention to the correct position of the kidney-shaped orifices in the valve seats and to the correct positions of the bores in the head covers (circles in figure above)!
- ➔ Put the valves (D) in place. See figures above for the correct position of the valves:
 - Inlet side** of pump head: The valve tongue points at the kidney-shaped orifice in the valve seat.
 - Outlet side** of pump head: The valve is oriented the opposite direction as the valve at the inlet side. Round orifice under the valve tongue.
 - MZ 1C:** Put the white PTFE valves (see figure above) at the outlet of the first pump stage and at the inlet of the second stage!

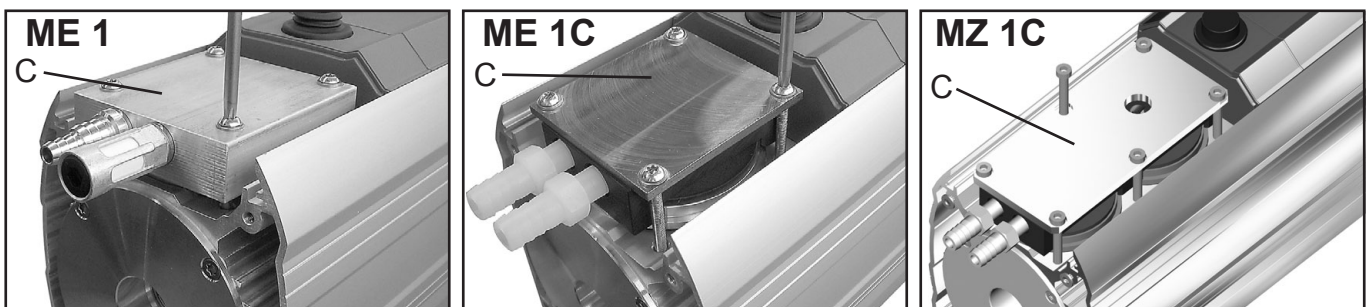

- ➔ Put on housing cover (C) (ME 1) or housing cover (C) and housing cover insert (C1) (ME 1C / MZ 1C).
- ☞ Move housing cover or housing cover insert slightly to ensure that the head covers are correctly positioned.

ME 1 / ME 1C:

- ➔ Screw in 4 screws with washers at the housing cover diagonally at first slightly with a Torx driver T20, then tighten.
- ☞ Do **not** tighten until head cover is in contact with housing, maximum torque: 2.2 ft·lb_f (3 Nm).

MZ 1C:

- ➔ Screw in 6 screws at the housing cover diagonally at first slightly with a 4mm wide Allen key, then tighten.
- ☞ Do **not** tighten until head cover is in contact with housing, maximum torque: 4.4 ft·lb_f (6 Nm).

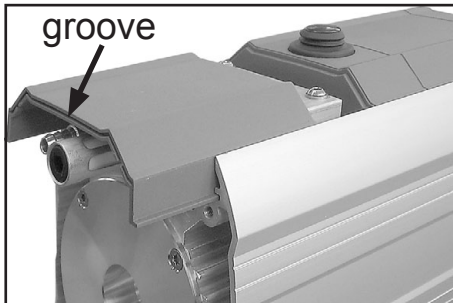

- ➔ Assemble the cover (B) so that the groove in the cover is at the front side of the pump.

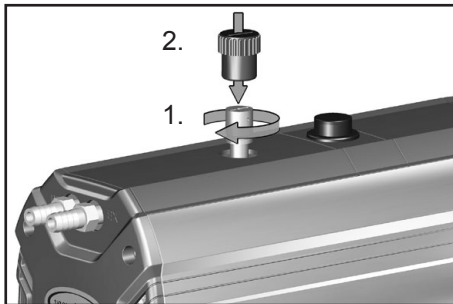
**Only MZ 1C:**

- ☞ If necessary, wind the thread of the gas ballast tube two times counterclockwise with PTFE bond to avoid leaks. Ensure that the PTFE bond ends flush with the gas ballast tube.

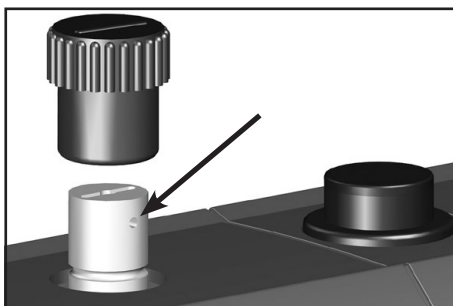

- ➔ Screw the gas ballast tube in the housing cover insert, use a slotted screwdriver if necessary.
- ☞ Pay attention to the correct orientation of the bore in the gas ballast tube, see figure.
- ➔ Put the gas ballast cap onto the gas ballast tube.



- ➔ Put front cover (A) on.
- ➔ Install the washers. Use a Torx driver T20 to attach the 4 screws holding the cover. Maximum torque: 2.2 ft·lb_f (3 Nm).

Checking the ultimate vacuum

- ➔ After any intervention at the equipment (e.g., repair / maintenance) the ultimate vacuum of the pump has to be checked. Only if the pump achieves its specified ultimate vacuum, the pump's leak rate is low enough to ensure that no explosive atmospheres will occur in the interior of the equipment.

If the pump does not achieve the ultimate vacuum:

- Whenever the diaphragms and valves have been replaced, a break-in period of several hours is required before the pump achieves its ultimate vacuum.
- In case of an unusual noise, switch off pump immediately and check clamping disc positions.

If the specified ultimate vacuum is not achieved, and if this does not change after the break-in period:

If necessary recheck valve seats and pump chambers.

Replacing the fuse

! DANGER



- ➔ **Switch off the pump.**
- ➔ **Disconnect the electrical power cord** before removing the covers. After disconnecting from power, **wait two minutes** to allow the capacitors to discharge.

! WARNING

- ☞ The replacing of the fuse has to be carried out by a trained electrician.
- ☞ After replacing the fuse, the pump must be checked for electric safety (see below)! Identify and eliminate the cause of failure before switching on the pump again.

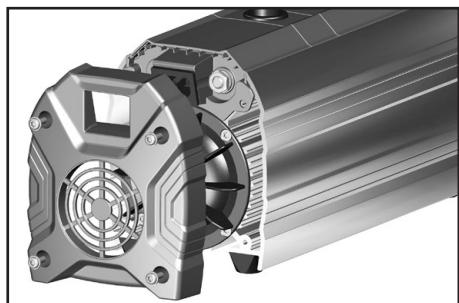

- ➔ Remove the 4 screws affixing the back cover with a Torx driver T20 to replace the fuses. Pay attention to the washers under the screws.
- ➔ Pull off front cover carefully. Do not tilt.

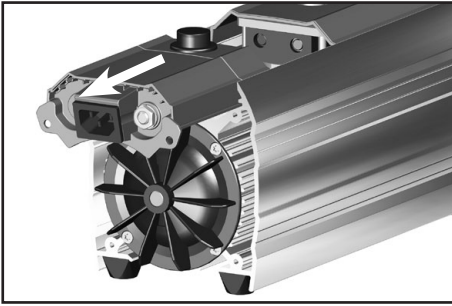

- ➔ Slide the cover containing the electrical system carefully aside. Remove the cover completely from the pump. **Attention:** The electrical system (wires and capacitors) is integrated inside the cover!



②

①

②

- ☞ The pigtail fuses are integrated into wires ((1), black and blue) between the power connection and the ON/Off switch. To replace the fuses it is necessary to replace both wires completely (fixed with flat pin bushings (2)).
- ➔ Remove both wires with integrated fuses (fixed with flat pin bushings (2), see figure). Mount the new wires (flat pin bushings)

- ➔ Slide the cover with the integrated electrical system back onto the pump housing. Be careful not to squeeze or damage any wires.
- ➔ Put back cover on.
- ➔ Install the washers. Use a Torx driver T20 to attach the 4 screws holding the cover.
Maximum torque: 2.2 ft·lb_f (3 Nm).

Order-no. Set of fuses **636050 + 636051**

⚠ WARNING

Important: Check operability and safety of the pump after repair and after replacing the device fuse.

Check the electrical safety (protective conductor resistance, insulating resistance, high voltage test) according to IEC 61010 and national regulations.

Notes on return to the factory

Repair - return - DAkkS calibration

NOTICE

Safety and health of our staff, laws and regulations regarding the handling of dangerous goods, occupational health and safety regulations and regulations regarding safe disposal of waste require that for all pumps and other products, the "Health and safety clearance form", pg. 54, must be sent to our office fully completed and signed before any equipment is shipped to the authorized service center.

Fax or mail a completed copy of the health and safety clearance form to us in advance. The declaration must arrive before the equipment. **Enclose a second completed copy with the product.** If the equipment is contaminated, you must notify the carrier.

No repair / DAkkS calibration is possible unless the correctly completed form is returned. Inevitably, there will be a delay in processing the equipment if information is missing, or if this procedure is not followed.

CAUTION

If the product has come in contact with chemicals, radioactive substances or other substances dangerous to health or environment, the product must be decontaminated **prior to sending it back to the service center.**

- Return the product to us disassembled and cleaned and accompanied by a certificate verifying decontamination or
- Contact an industrial cleaning and **decontamination service** directly or
- Authorize us to send the product to an industrial cleaning facility **at your expense.**

To expedite repair and to reduce costs, please enclose a detailed description of the problem and the product's operating conditions with every product returned for repair.

We submit **repair quotations** only on request and always at the customer's expense. If an order is placed, the costs incurred for problem diagnosis are offset from the costs for repair or from the purchase price, if the customer prefers to buy a new product instead of repairing the defective one.

- **If you do not wish a repair on the basis of our quotation, the equipment may be returned to you disassembled and at your expense.**

In many cases, the **components must be cleaned in the factory** prior to repair.

For cleaning we use an environmentally friendly water-based process. Unfortunately the combined attack of elevated temperature, cleaning agent, ultrasonic treatment and mechanical stress (from pressurized water) may result in damage to the paint. Please mark in the health and safety clearance form, if you wish a **repaint at your expense** just in case such a damage should occur.

We will also replace parts for cosmetic reasons at your request and at your expense.

NOTICE

Before returning the equipment, ensure that (if applicable):

- Oil sealed pumps: Oil has been drained and an adequate quantity of fresh oil has been filled in to protect against corrosion. Dispose according to regulations.
- Equipment has been cleaned and/or decontaminated (inside and outside).
- All inlet and outlet ports have been capped.
- Equipment has been properly packed, (if necessary, please order original packaging materials at your cost), marked appropriately and the carrier has been notified of any possible contamination.
- The completed health and safety clearance form is enclosed.

We thank you in advance for your understanding of the necessity for these measures that protect our employees, and ensure that your pump is protected in shipment.

Scrapping and waste disposal:

Dispose of the equipment and any components removed from it safely in accordance with all local and national safety and environmental requirements. Particular care must be taken with components and waste oil which have been contaminated with dangerous substances from your processes. Do not incinerate fluoroelastomer seals and O-rings.

- You may authorize us to dispose of the equipment **at your expense.**

Warranty

VACUUBRAND shall be liable for insuring that this product, including any agreed installation, has been free of defects at the time of the transfer of risk.

VACUUBRAND shall not be liable for the consequences of improper handling, use, servicing or operation of this product or the consequences of normal wear and tear of wearing parts such as diaphragms, seals, valves, vanes, condensers, oil and the breakage of glass or ceramic parts, for the consequences of chemical, electrochemical or electrical influences or the failure to follow the instructions in this manual.

Claims for defects against VACUUBRAND shall be limited to one year from delivery. The same shall apply to claims for damages irrespective of legal grounds.

For further information on general terms and conditions refer to www.vacuubrand.com.

Health and safety clearance form



Devices will not be accepted for any handling before we have received this declaration. Please read and comply with "Notes on return to the factory".
Oil filled pumps: Drain oil prior to shipping absolutely!

1. Device (Model): 2. Serial no.:

3. Reason for return / malfunction:
.....
.....

4. Has the device been used in a copper process step (e.g., semiconductor production). yes no

5. Substances (gases, liquids, solids) in contact with the device / which have been pumped:
.....
.....
.....

6. Prior to return to the factory the device has been decontaminated. yes no
Description of the decontamination method and the test / verification procedure:
.....
.....

7. The device is free of hazardous, harmful substances. yes no

8. Protective measures required for VACUUBRAND employees:
.....

9. If the paint is damaged, we wish a repaint or a replacement of parts for reason of appearance (repaint and replacement at customer's expense). yes no

10. Legally binding declaration

We assure for the returned device that all substances, which have been in contact with the device are listed in section 5 and that the information is complete and that we have not withheld any information. We declare that all measures - where applicable - have been taken listed in section "Return to the factory". By our signature below, we acknowledge that we accept liability for any damage caused by providing incomplete or incorrect information and that we shall indemnify VACUUBRAND from any claims as regards damages from third parties. We are aware that as expressed in § 823 BGB (Public Law Code of Germany) we are directly liable for injuries or damages suffered by third parties, particularly VACUUBRAND employees occupied with handling/repairing the product.
Shipping of the device must take place according to regulations.

Name: Signature:

Job title: Company's seal:

Date:

Release for repair grant by VACUUBRAND (date / signature):

VACUUBRAND GMBH + CO KG
Alfred-Zippe-Straße 4
97877 Wertheim, Germany

Tel.: +49 9342 808-5660
Fax: +49 9342 808-5666
E-Mail: service@vacuubrand.com
www.vacuubrand.com



**EG-Konformitätserklärung für Maschinen
EC Declaration of Conformity of the Machinery
Déclaration CE de conformité des machines**

Hersteller / Manufacturer / Fabricant:

VACUUBRAND GMBH + CO KG · Alfred-Zippe-Str. 4 · 97877 Wertheim · Germany

Hiermit erklärt der Hersteller, dass die Maschine konform ist mit den Bestimmungen der Richtlinie 2006/42/EG.

Hereby the manufacturer declares that the machinery is in conformity with the directive 2006/42/EC.

Par la présente, le fabricant déclare, que la machine est conforme à directive 2006/42/CE.

Membranvakuumpumpe / Diaphragm vacuum pump / Pompe à membrane:

Typ / Type / Type: ME 1 / ME 1C / MZ 1C

Artikelnummer / Order number / Numéro d'article: 721000, 721001, 721002, 721005 / 721100, 721101, 721102, 721105 / 724100, 724102, 724105, 724106

Seriennummer / Serial number / Numéro de série: Siehe Typenschild / See rating plate / Voir plaque signalétique

Die Maschine ist konform mit weiteren Richtlinien / The machinery is in conformity with other directives / La machine est conforme à d'autres directives:

2006/95/EG, 2004/108/EG

Angewandte harmonisierte Normen / Harmonized standards applied / Normes harmonisées utilisées:

DIN EN 12100, DIN EN 61010-1, DIN EN 1012-2, DIN EN 61326-1

Bevollmächtigter für die Zusammenstellung der technischen Unterlagen / Person authorised to compile the technical file / Personne autorisée à constituer le dossier technique:

Dr. J. Dirscherl · VACUUBRAND GMBH + CO KG · Alfred-Zippe-Str. 4 · 97877 Wertheim · Germany

Wertheim, 13.07.2012

Ort, Datum / place, date / lieu, date



(Dr. F. Gitmans)
Managing director / Gérant

ppa.

(Dr. J. Dirscherl)
Technischer Leiter / Technical Director /
Directeur technique



VACUUBRAND GMBH + CO KG
Alfred-Zippe-Str. 4 · 97877 Wertheim
T +49 9342 808-0 · F +49 9342 808-5555
info@vacuubrand.com
www.vacuubrand.com

<h1>Certificate</h1>		 TÜVRheinland®
Certificate no.		CU 72111636 01
License Holder: VACUUBRAND GMBH + Co. KG Alfred-Zippe-Str. 4 97877 Wertheim Germany	Manufacturing Plant: VACUUBRAND GMBH + Co. KG Alfred-Zippe-Str. 4 97877 Wertheim Germany	
Test report no.: USA- 31181600 001		Client Reference: M. von Przychowski
Tested to: UL 61010-1:2004 R10.08 CAN/CSA-C22.2 NO. 61010-1-04+GI1 (R2009)		
Certified Product: Diaphragm Vacuum Pump for Laboratory Use	License Fee - Units	
Model Designation: ME 1zzz; VP 100z z = A-Z, blank	7	
Rated Voltage: 1) AC 100-120V, 50/60Hz or 2) AC 230V, 50/60Hz or 3) AC 100-120V/200-230V, 50/60Hz		
Rated Current: 1) 1.9A, 2) 0,8A, 3) 1.9/0.8A		
Protection Class: I		
Appendix: 1, 1-2	7	
Licensed Test mark: 	Signature  <hr/> Dipl.-Ing. G. Engels QA Certification Officer	Date of Issue (day/mo/yr) 12/08/2011
<small>TÜV Rheinland of North America, Inc., 12-Commerce Road, Newtown, CT 06470, Tel (203) 426-0888 Fax (203) 426-4009</small>		

This certificate is only valid for pumps with the respective mark (Licensed Test mark) on the pump rating plate.

Disclaimer: Our technical literature is only intended to inform our customer. The applicability of general empirical values and results obtained under lab conditions to your specific operations depends on a number of factors beyond our control. It is, therefore, strictly the users' responsibility to very carefully check the application of these data to their specific requirements. No claims arising from the information provided in this literature will, consequently, be entertained.



Alfred-Zippe-Str. 4 · 97877 Wertheim / Germany
T +49 9342 808-0 · F +49 9342 808-5555
info@vacuubrand.com · www.vacuubrand.com

VACUUBRAND GMBH + CO KG
- Technology for Vacuum Systems -
© 2012 VACUUBRAND GMBH + CO KG Printed in Germany